

# Community of Iliamna

## Visioning Report

December 1992

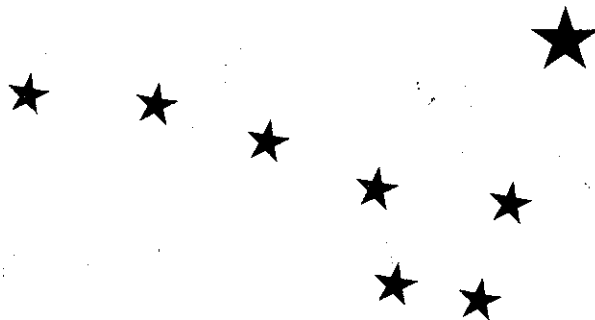

# Iliamna's Future

The residents of Iliamna have a responsibility to the community. Last Spring a group of residents demonstrated their willingness to accept this responsibility by working hard to identify a vision to guide the future of Iliamna. They attended community meetings in the evenings and on weekends and talked among themselves about the future and goals the community should work toward. They also discussed actions that could be taken by residents to improve the community. This is a summary of the results of their efforts.

The effort began with community meetings in February 1992 and continued through mid April 1992. Everyone was welcome to participate in those meetings. Notices were sent to each post office box holder and also posted in public places. During this period, every Iliamna box holder also received a questionnaire asking for their opinions on Iliamna's future. The results of this survey were reviewed and considered during the community meetings.

What were the products of these efforts? The first major product of the community meetings was a goal statement for the community. That goal was developed in response to a question:

What should the goal of the community of Iliamna be for the next 10 years?

# ILIAMNA VISION RESULTS

**Community develops guiding principle for the future:**

Through individuals working together for a better community, Iliamna will maintain the quality of life, where residents and visitors respect the people, land, resources and cultures of the community.

**Community Develops Action Plans for:**

Health  
Education  
Economy  
Lifestyle  
Governance  
Community  
Facilities

# HEALTH

## GOAL STATEMENT

The residents of Iliamna want to maintain and improve existing health care services by upgrading the existing clinic and equipment and continuing the training of Health Aides and community health care volunteers.

## ACTION PLAN

To achieve the Health goal, the residents of Iliamna have identified the following actions:

- ★ Organize a community effort to inform lodge owners and seasonal businesses on the services provided by the clinic and the importance of these services to their clients.
- ★ Seek contributions from businesses and residents for better equipment for the clinic.
- ★ Encourage continued training for the health aides and community volunteers.
- ★ Establish programs for: Substance Abuse, AIDS Awareness, Suicide Prevention, and Planned Parenthood.

# EDUCATION

## GOAL STATEMENT

The residents of Iliamna want to improve educational facilities and opportunities for youths and adults.

## ACTION PLAN

To achieve the Education goal, the residents of Iliamna have identified the following actions:

- ★ Demonstrate the community's appreciation for the high caliber of educational services provided by the high school.
- ★ Seek out opportunities for vocational education in Iliamna.
- ★ Work with Bristol Bay Branch College to establish courses that may be offered to the Iliamna communities in Iliamna.

# ECONOMY

## GOAL STATEMENT

The residents of Iliamna want to provide for economic opportunities for residents and for the children who must now relocate elsewhere to find gainful employment.

## ACTION PLAN

To achieve the Economic goal, the residents of Iliamna have identified the following actions:

- ★ To support local businesses that provide employment opportunities for residents.
- ★ Encourage local residents to develop businesses that can provide employment opportunities and keep money in the community.
- ★ Develop communication between the lodges and the community that will result in more local people being hired for seasonal lodge jobs. This includes understanding what the lodges want from employees and what local residents can offer.
- ★ Encourage residents to look at lodge operations and clients as an economic opportunity.
- ★ Encourage continued support for the hydro-electric project.

# LIFESTYLE

## GOAL STATEMENT

The residents of Iliamna want to maintain the unique, wholesome qualities of life associated with small rural Alaska communities and avoid the problems of urban life.

## ACTION PLAN

To achieve the Lifestyle goal statement, the residents of Iliamna have identified the following actions:

- ★ Support local subsistence activities.
- ★ Seek support for the subsistence concept at the federal, state and local government level.
- ★ Take responsibility to keep the community clean.
- ★ Community and lodges sponsor a clean-up day and picnic each Spring.
- ★ No toleration for "drug" dealing or alcohol trafficking.

# GOVERNANCE

## GOAL STATEMENT

Iliamna residents want to be kept informed on issues pertaining to local governance and to take action only as it becomes necessary.

## ACTION PLAN

To achieve the Governance goal, the residents of Iliamna have identified the following actions:

- ★ Issues should only be dealt with as they become issues of importance to the community.
- ★ Efforts should be made not to upset the working relationship that exists between the various groups of people within the community.
- ★ Residents want to be kept informed of the issues concerning Iliamna's governance.
- ★ Efforts should be made to keep the communications with Newhalen open.
- ★ Residents should be kept informed of borough actions.
- ★ Iliamna and Newhalen residents need to work towards a healing between the two communities.
- ★ Iliamna needs to develop a sense of community focus.
- ★ Seek ways to keep the State Trooper in Iliamna.

# COMMUNITY

## GOAL STATEMENT

The residents of Iliamna want to maintain the friendliness and neighborliness of the community, encourage active participation by all members of the community and to improve relations and communications between residents and seasonal business operators.

## ACTION PLAN

To achieve the Community goal, the residents of Iliamna have identified the following actions:

- ★ Set up a series of meetings with residents and lodge operators and staff.
- ★ Conduct winter community functions such as a carnival, pot lucks, and recreational activities for all ages.
- ★ Provide information on community services to campers and sports fishermen and inform them how to respect community concerns.

# FACILITIES

## GOAL STATEMENT

Iliamna residents want to have facilities that improve the quality of life, and are financially supportable, cost-effective and based on existing and foreseeable future needs.

## ACTION PLAN

To achieve the Facilities goal, the residents of Iliamna have identified the following actions:

- ★ Identify and select 14(c)(3) sites to settle this issue.
- ★ Identify operational and maintenance costs of existing and proposed facilities.
- ★ Develop a landfill operation and maintenance plan.
- ★ Identify a sewage lagoon site.
- ★ Identify sites for parks and recreational areas.
- ★ Identify sites for future public buildings and an elders home.
- ★ Respect the land holdings of INL and APC.

# Overview

## What is visioning?

**Visioning is a community based process that creates a picture of the community's desired future.**

Visioning is the residents of a community establishing a picture of a desired future for the community. From this "vision," a series of steps are identified by the residents that will achieve this future. The distinguishing aspects of visioning, as opposed to more traditional community planning, is that all ideas spring from the residents instead of hired or professional planners; visioning emphasizes consensus building; visioning is not single focused on one aspect of the community, but encompasses a universe of actions that lead to an envisioned future. The success of visioning is based on broad support of the community and the residents' commitment to achieving the vision; visioning empowers the community.

### **History of Iliamna's visioning**

In March 1992 the village of Iliamna began a process to sharpen the community's goals and establish a direction for future actions. This process relied upon discussions at community meetings, a survey of residents, and building of consensus among residents. The procedure was similar to that applied in other communities in Alaska and in the lower 48 states, and is referred to as "visioning" by the professional planning community.

DCRA staff were asked by the Municipal Lands Trustee to attend a meeting in Iliamna on March 3, 1992, to explain the process of visioning to residents at a community meeting. The Municipal Land Trustee had earlier discussed with the village corporation using this technique to get the community to constructively participate in the settlement of the ANCSA 14(c)(3) issue. The corporation had agreed to participate in this approach to overcome past divisiveness in the community on this issue.

**MARCH 3, 1992**

### **VISIONING EXPLAINED**

The concept of visioning was explained at the March 3rd meeting and the results of a similar process conducted for the community of Unalaska described. Staff asked those in attendance if they would like to embark on a similar process. The answer was an overwhelming "yes." Residents were reminded that DCRA staff would only facilitate the visioning process and that residents would determine its success through their energy and willingness to work for a better future. The attendees pledged to work together and attempt to interest the rest of the community in becoming involved.

### **ILIAMNA VISIONING SCHEDULE**

Having established that there was a desire for community visioning, DCRA staff outlined a process that could be used and a schedule of activities. DCRA committed to facilitate at least three community meetings, provide technical support to the community, conduct a survey of residents, and prepare a report to the community with the results of the effort. The

residents attending committed to continuing to participate, help with the survey of residents, work together toward consensus, and continue the effort after DCRA's job was completed.

## **FUTURE STATEMENTS DEVELOPED**

At the conclusion of the meeting, the facilitators initiated the process of group discussion of Iliamna's desired future. The attendees were organized into groups of four or five. Individuals were asked first to consider the changes they desired for the community over the next 10 years. They were asked to write these statements and then each member of the group would share their statements with the group.

As these "visions" were offered, an individual selected by the group recorded the statements on flip charts. Following the input of each member, the groups selected a spokesperson to summarize the statements and report the results to the entire body. Each group placed their flip charts on the walls so they were clearly visible to all attendees and talked from the charts. At the conclusion of each group's presentation, discussion and clarification were encouraged from other members of that group and from other groups. The results of this exercise were a diverse and large number of desired futures offered by residents for the community.

## **COMMUNITY SURVEY**

Following this meeting, these statements were used by DCRA to fashion a community survey. The survey attempted to measure the level of agreement in the community on what the people wanted for the future. The questionnaire was sent to all box holders in the community. Additional questionnaires were

available at public places in the community. Completed questionnaires were collected by a few volunteers in the community and sent to DCRA at the end of two weeks. DCRA summarized the results, and created a series of graphics and charts to better communicate the survey results.

## **MARCH 31 - APRIL 1**

### **SURVEY RESULTS**

The results of the survey were presented at a March 31 - April 1 meeting. An exercise was devised to creatively present the survey results to the attendees. In addition, the results were organized in report form and made available to those who attended following the March 31 meeting.

### **VISION STATEMENT DEVELOPED**

On April 1, the meeting attendees were organized into two groups and asked to work on an overall vision statement. The groups made presentations of their statements after their work and then as a whole combined the ideas of both smaller groups. A statement built upon consensus of those participating emerged as Iliamna's Vision.

### **ESTABLISHING CATEGORIES**

Following the work on a community vision, the groups began work on goals for several categories of community issues. These several categories were identified by organizing desires and issues expressed in the survey results. To help the

process of goal setting, DCRA facilitated the creation of a goal statement for the Health issue using the whole group.

## **GOAL SETTING**

The whole group followed the setting of a Health goal by identifying the strengths and barriers of Iliamna in achieving the goal. After having considered the strengths of Iliamna and the assets of the community in the Health issue, the group discussed the barriers or obstacles that Iliamna faced in achieving the Health goal. This exercise allowed the participants to identify some actions the community could undertake to enhance its strengths and overcome its barriers. An action plan for the Health goal resulted.

**APRIL 18**

## **COMMUNITY MEETING**

On April 18, another community meeting was organized. At this meeting, a small number of participants worked as one group to devise goals for the remaining six categories of issues. The goal setting exercise was followed by a brief discussion of barriers and strengths for each category.

## **ACTION PLANS FOR GOALS**

The final exercise was a group formulation of action plans for each goal. The group relied upon the ideas offered at previous meetings for most of the ideas expressed in the action plans.

**NOVEMBER 19**

## **COMMUNITY MEETING**

The final community meeting was held on November 19, 1992. Nine residents of Iliamna attended. The group reviewed the goals and action plans which were formulated in April. One conclusion the group came to was that better communications will be necessary if the actions plans are to be effectively implemented.

The last item discussed was how to proceed with the ANCSA 14(c)(3) identification process. It was decided that a 14(c)(3) committee should be formed consisting of two (2) members from the village corporation, two (2) members from the village council and three (3) members from the community at large. This process was made contingent on village corporation approval. This committee would work with the Municipal Land Trustee Program in DCRA to identify potential ANCSA 14(c)(3) conveyances.

## **Attachments**

- Meeting Participants
- Iliamna Community Meeting, March 3, 1992
- Community Survey
- Community Survey Results
- Iliamna Community Meeting, March 31 - April 1, 1992
- Iliamna Community Meeting, April 17, 1992
- Iliamna Community Meeting, November 19, 1992.

**Meeting Participants**

**PARTICIPANTS IN  
ILIAMNA COMMUNITY MEETINGS**

**March 3, 1992**

Bob Arce  
Sue Arce  
Bert Foss  
Tim LaPorte  
Sally Moses-Baechler  
David M. Parks  
Elia Anelon  
Myrtle Anelon  
Etael Adcox  
John Adcox

**April 18, 1992**

Maria Anelon  
Harvey Anelon  
John Adcox  
Ethel Adcox  
Harry Ricci  
Sally Mosco-Baechler

**November 19, 1992**

**March 31, 1992 and  
April 1, 1992**

Maria Anelon  
Harvey Anelon  
David Parks  
Bob Arce  
Harry Ricci  
Robert Drew  
Edna Foss  
James Drew  
Trig Olson  
Ethel Adcox  
Hans Roehlet  
John W. Johnson  
Lorene A. Arce  
John Adcox

John Adcox  
Bob Arce  
Richard Harkness  
John W. Johnson  
Norm Aaberg  
Laura Aaberg  
Ethel Adcox  
Trig Olson  
Tim LaPorte

**Iliamna Community Meeting**

**March 3, 1992**

# **Iliamna Community Meeting**

**March 3, 1992**

**Rick Elliott**

**Natural Resource Manager  
Municipal Lands Trustee**

**Jim Sanders**

**Local Government Specialist**

**Mike Black**

**Local Government Specialist**

**Iliamna Meeting Agenda**  
**March 3, 1992**

- 7:00 PM    Welcome
- Introductions
- Overview of Tonight's Meeting
- 7:30 PM    Exercise on Perception
- Explanation of Visioning  
            Overview  
            Unalaska Experience
- 8:00 PM    Break
- 8:10 PM    Break into Groups
- Exercise - Word Game
- Group Discussion/Decision on Iliamna Visioning
- Group Decision Reports
- 9:00 PM    Break
- 9:10 PM    Group Discussion of Future Desires  
            Instruction to Groups  
            Individual Work  
            Group Discussion
- 10:00 PM    Break
- 10:10 PM    Report of Groups
- 10:30 PM    Wrap Up & Summary

## House Keeping

## Why Are We Here?

- Ask to facilitate by Municipal Lands Trustee
- Offer the community a process to reach agreement
- Try out a new process

## What Do We Expect to Have Happen?

- ✓ Listen to us for 1 hour.
- ✓ We will listen to you for 2 hours.

## What Do You Want To Happen Tonight?

# Visioning

## What Is Visioning?

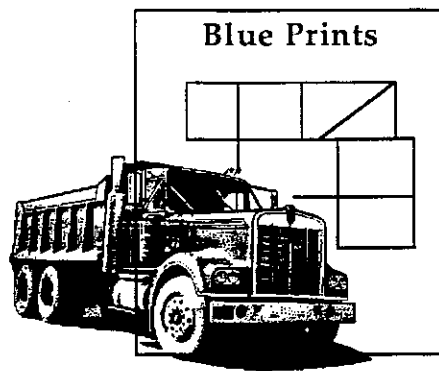

**Project Plan**



**Community Based**  
**Built on Consensus**  
**Shared Responsibility**  
**Cooperation**  
**Leadership From Shared Vision**  
**Broad Support**  
**Power Resides In The Community**

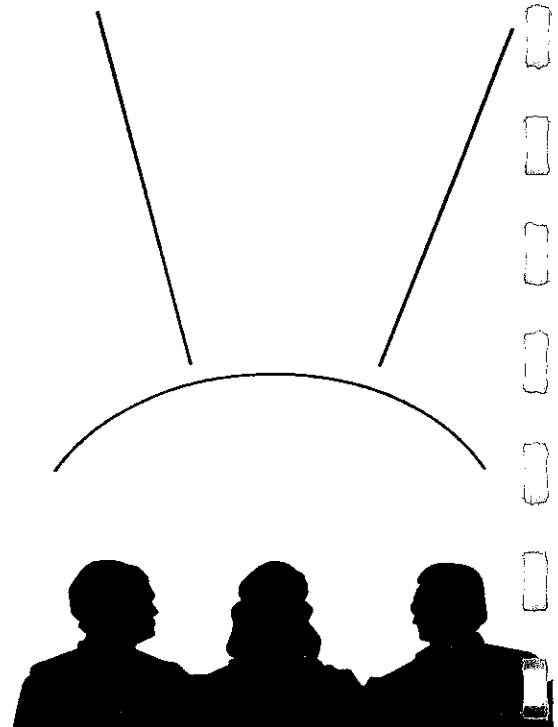

# Why Visioning?



**Local Problems  
Are Best Solved  
By  
Local People**

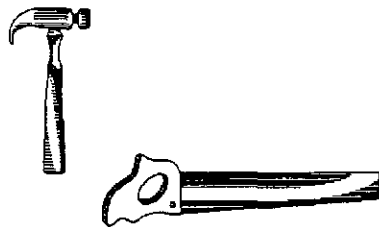

**People Support  
What They Help Create**

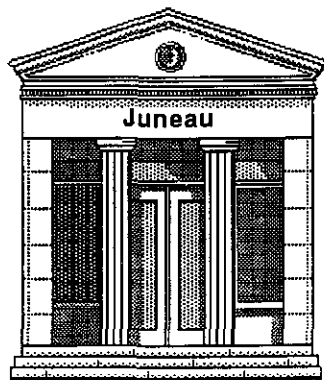

**Government  
Doesn't Have Answers  
Only  
Resources**

# How Is Visioning Done?

## **Step 1      Community Support**

**Community agrees to work**

- ? Do you have energy?**
- ? Do you have desire to mobilize?**
- ? Are you willing to work for a better future?**

## **Step 2      Community Participation**

**Consensus Building Meeting**

**Survey of needs, desires, etc.**

## **Step 3      Community Vision and Purpose**

**Statements of Desired Future (Where we want to be.)**

**Identify Resources and Obstacles**

**Develop Plan for Achieving Vision**

**Set Priorities**

## **Step 4      Community Action**

**Community Responsible for Action**

**Review the Vision and Planned Actions**

**Remodel Every So Often**

# UNALASKA

Community VISIONS  
For the Future

WHY?

- ✓ uncontrolled rapid growth
- ✓ loss of a sense of community
- ✓ community needs not being met

# **UNALASKA**



## **VISIONING PROCESS**



**Community Leaders Vision Statement**

---

**Survey**

---

**Community Vision Statement**

---

**Community Action Agenda**

# UNALASKA VISION

---

---

## Questions to be Answered

---

---



If the citizens and the City of Unalaska were to work together to enhance the community over the next 5 to 10 years, what would you like to see result from those efforts?

---

---



What are the obstacles or issues that will be facing the community over the next 5 years that must be addressed to reach your preferred Vision?

---

---



What actions are now being taken or should be taken to address these issues

---

---



What are the major existing strengths of the community that should be stressed to reach your preferred Vision?

---

---



By the year 2000, what would you like to see Unalaska become known for as?

---

---

# UNALASKA

## *Vision Outcomes*

---

---

★★★ Community Goals & Values ★★★

- ✓ Quality of life
- ✓ Managed growth & assertive planning
- ✓ Participatory governance
- ✓ Resource management & protection
- ✓ Economic diversification & stability
- ✓ Image

# UNALASKA VISION

## ✓ *Quality of Life*

Providing a broader & more balanced assortment of health care facilities & services within the community

Continuing efforts to maintain the highest level of local educational opportunities for local residents

Placing greater emphasis on the development of quality and affordable housing

Providing a higher level of recreational facilities & services within the community

**Department of Community and Regional Affairs  
(DCRA)  
and  
Community of Iliamna**

**Commit to doing what is necessary to establish future goals for Iliamna and identifying what we need to do to reach them.**

**The community commits to:**

- ✓ **Three meetings.**
- ✓ **Survey of Residents.**
- ✓ **Accept Work Assignments.**
- ✓ **Work Together Toward Consensus.**
- ✓ **Continue After DCRA leaves.**

**DCRA commits to:**

- ✓ **Facilitate three meetings.**
- ✓ **Help conduct survey.**
- ✓ **Assist Community.**
- ✓ **Prepare a report to Iliamna (write, print, copy).**
- ✓ **Publicize Community Vision.**
- ✓ **Do our best as resources and time permits.**





# ILIAMNA VISIONING



## Individual Desires for Iliamna



There are several simple steps to doing this exercise.



1.) Take a few minutes and think about the community of Iliamna.



2.) After you have a picture of Iliamna, its strengths and weakness, consider the changes you would like for Iliamna 10 years from now.

3.) Write down what you desire for the community of Iliamna's future. 

---



---



---



---



---



---



---



---



---



---



# ILIAMNA VISIONING



## Group Desires for Iliamna



Now it's time to share your vision of Iliamna's future with the members of your group. The group's recorder will write down the desires on the flip chart.



If there are duplicate ideas, don't write the statement again, just put a check mark by the original.



This isn't an exercise to get consensus on ideas so record all ideas and don't worry about agreement on statements by all group members.



After all the "desires" are recorded, each group speaker will report the group's ideas to the full group meeting. Those ideas will be the basis for the community survey and the next meeting.



Next meeting scheduled for: \_\_\_\_\_

# Wrap Up

**Next Meeting**

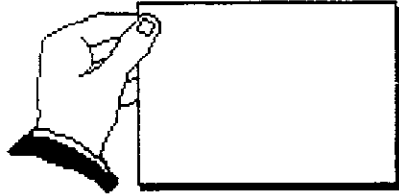

**Survey**



**Assignments**



**Community Contract**

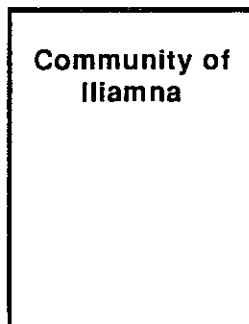

**Community Survey**

## What's The Future of Iliamna?

That was the question asked of a group of Iliamna residents that met on March 4. The meeting was the initial public meeting of a project to look at what the residents of our community want to have happen in Iliamna over the next 10 years. Another meeting to explore the future of our community is scheduled for March 31. Everyone is invited to participate.

To prepare for this meeting we are asking all residents to let us know what you want to have happen in Iliamna to improve the community. By filling out the attached questionnaires we can record your ideas. Two questionnaires are provided to each household. If additional questionnaires are needed, please contact Myrtle Anelon or Ethel Adcox.

The questions on the next pages ask how you would like to see the quality of life in Iliamna improved over the next 10 years. Please complete the

questionnaire. Your opinion is important. The information you provide will be used to shape Iliamna's community vision.

The questionnaires must be completed and turned in by March 15. You may turn the questionnaires in at the post office, community store, Iliamna Air Taxi office, or the Iliamna Village Council Office.

The next visioning meeting will be on March 31 in Iliamna. Prior to the meeting, the questionnaire results will be summarized. The questionnaire results will be shared at the meeting and additional work in developing a community vision will occur. We encourage you to attend that meeting.

Thank you for taking the time to complete this questionnaire. By working together, the residents of Iliamna can best improve and protect the community's quality of life now and in the future.

Return completed questionnaire to:  
Post Office, Community Store,  
Iliamna Air Taxi or Village Council office

**Iliamna Boxholder  
Iliamna, AK 99606**

## Part I

The items below were listed as desires or preferences by individuals who participated in a "Visioning" session in Iliamna on March 4, 1992. Please indicate if you think each of these items should be *Very Important*, *Somewhat Important*, or *Not Important* to improving your quality-of-life in Iliamna over the next 10 years. (Please check only one response for each item listed.)

Item	Very Important	Somewhat Important	Not Important
1. Having a community wide water system.	<input type="checkbox"/>	<input type="checkbox"/>	<input type="checkbox"/>
2. Having a community wide sewer system.	<input type="checkbox"/>	<input type="checkbox"/>	<input type="checkbox"/>
3. Having better employment opportunities for future generations (young people)	<input type="checkbox"/>	<input type="checkbox"/>	<input type="checkbox"/>
4. Maintaining subsistence opportunities for residents	<input type="checkbox"/>	<input type="checkbox"/>	<input type="checkbox"/>
5. Improving health care facilities and services	<input type="checkbox"/>	<input type="checkbox"/>	<input type="checkbox"/>
6. Having better educational opportunities in secondary schooling	<input type="checkbox"/>	<input type="checkbox"/>	<input type="checkbox"/>
7. Having better educational opportunities in vocational schooling	<input type="checkbox"/>	<input type="checkbox"/>	<input type="checkbox"/>
8. Having better facilities for disposing of garbage, such as landfills.	<input type="checkbox"/>	<input type="checkbox"/>	<input type="checkbox"/>
9. Having a community library	<input type="checkbox"/>	<input type="checkbox"/>	<input type="checkbox"/>
10. Having a way to handle the large number of seasonal sport fishermen and hunters	<input type="checkbox"/>	<input type="checkbox"/>	<input type="checkbox"/>

Item	Very Important	Somewhat Important	Not Important
11. Having designated camping areas for visitors	<input type="checkbox"/>	<input type="checkbox"/>	<input type="checkbox"/>
12. Having recreational opportunities for residents and youth, such as ball fields	<input type="checkbox"/>	<input type="checkbox"/>	<input type="checkbox"/>
13. Better disposal of hazardous waste	<input type="checkbox"/>	<input type="checkbox"/>	<input type="checkbox"/>
14. Recycling of disposable products	<input type="checkbox"/>	<input type="checkbox"/>	<input type="checkbox"/>
15. Maintaining the existing quality of life	<input type="checkbox"/>	<input type="checkbox"/>	<input type="checkbox"/>
16. Having a subregional clinic in Iliamna	<input type="checkbox"/>	<input type="checkbox"/>	<input type="checkbox"/>
17. Controlling the rate of growth in the community	<input type="checkbox"/>	<input type="checkbox"/>	<input type="checkbox"/>
18. Better planning of future development of the community	<input type="checkbox"/>	<input type="checkbox"/>	<input type="checkbox"/>
19. Having a functional day care in the community	<input type="checkbox"/>	<input type="checkbox"/>	<input type="checkbox"/>
20. Having no taxes for residents or businesses	<input type="checkbox"/>	<input type="checkbox"/>	<input type="checkbox"/>
21. Improved communication between the cultural segments of the community	<input type="checkbox"/>	<input type="checkbox"/>	<input type="checkbox"/>
22. Regaining the cultural heritage of the Native culture	<input type="checkbox"/>	<input type="checkbox"/>	<input type="checkbox"/>
23. Having the community work together better on future issues	<input type="checkbox"/>	<input type="checkbox"/>	<input type="checkbox"/>

Item	Very Important	Somewhat Important	Not Important
24. Community support for local businesses	<input type="checkbox"/>	<input type="checkbox"/>	<input type="checkbox"/>
25. Encouraging new business opportunities	<input type="checkbox"/>	<input type="checkbox"/>	<input type="checkbox"/>
26. Having park areas available for community use	<input type="checkbox"/>	<input type="checkbox"/>	<input type="checkbox"/>
27. What are your desires for Iliamna that are not listed above and you think are important to improving the community. Please describe and rank.			

_____	<input type="checkbox"/>	<input type="checkbox"/>	<input type="checkbox"/>
_____	<input type="checkbox"/>	<input type="checkbox"/>	<input type="checkbox"/>
_____	<input type="checkbox"/>	<input type="checkbox"/>	<input type="checkbox"/>
_____	<input type="checkbox"/>	<input type="checkbox"/>	<input type="checkbox"/>
_____	<input type="checkbox"/>	<input type="checkbox"/>	<input type="checkbox"/>
_____	<input type="checkbox"/>	<input type="checkbox"/>	<input type="checkbox"/>
_____	<input type="checkbox"/>	<input type="checkbox"/>	<input type="checkbox"/>
_____	<input type="checkbox"/>	<input type="checkbox"/>	<input type="checkbox"/>
_____	<input type="checkbox"/>	<input type="checkbox"/>	<input type="checkbox"/>
_____	<input type="checkbox"/>	<input type="checkbox"/>	<input type="checkbox"/>
_____	<input type="checkbox"/>	<input type="checkbox"/>	<input type="checkbox"/>
_____	<input type="checkbox"/>	<input type="checkbox"/>	<input type="checkbox"/>

## Part II

Of the items listed on the previous pages, please tell us which you think are the **Most Important** in improving the quality of life in Iliamna. Indicate **your top 10 priorities** by using the Number shown on the previous pages for each of the 26 items.

### Most Important Items

1st Priority # \_\_\_\_\_

6th Priority # \_\_\_\_\_

2nd Priority # \_\_\_\_\_

7th Priority # \_\_\_\_\_

3rd Priority # \_\_\_\_\_

8th Priority # \_\_\_\_\_

4th Priority # \_\_\_\_\_

9th Priority # \_\_\_\_\_

5th Priority # \_\_\_\_\_

10th Priority # \_\_\_\_\_

## Part III

What do you like most about Iliamna?

---

---

---

## Part IV

What do you like least about Iliamna?

---

---

---

**Community Survey Results**

## Survey

The items below were listed as desires or preferences by individuals who participated in a "Visioning" session in Iliamna on March 4, 1992. A survey was sent to everyone after the session and people were asked to indicate if they thought each of the items should be *Very Important*, *Somewhat Important*, or *Not Important* to improving the quality-of-life in Iliamna over the next 10 years.

1. Having a community wide water system.
2. Having a community wide sewer system.
3. Having better employment opportunities for future generations (young people).
4. Maintaining subsistence opportunities for residents.
5. Improving health care facilities and services.
6. Having better educational opportunities in secondary schooling.
7. Having better educational opportunities in vocational schooling.
8. Having better facilities for disposing of garbage, such as landfills.
9. Having a community library.
10. Having a way to handle the large number of seasonal sport fishermen and hunters.
11. Having designated camping areas for visitors.
12. Having recreational opportunities for residents and youth, such as ball fields.
13. Better disposal of hazardous waste.
14. Recycling of disposable products.
15. Maintaining the existing quality of life.
16. Having a subregional clinic in Iliamna.
17. Controlling the rate of growth in the community.
18. Better planning of future development of the community.
19. Having a functional day care in the community.
20. Having no taxes for residents or businesses.
21. Improved communication between the cultural segments of the community.
22. Regaining the cultural heritage of the Native culture.
23. Having the community work together better on future issues.
24. Community support for local businesses.
25. Encouraging new business opportunities.
26. Having park areas available for community use.
27. What are your desires for Iliamna that are not listed above and you think are important to improving the community. Please describe and rank.

Of the items listed, people were ask to indicate the **Most Important** item to improve the quality of life in Iliamna. People were asked to indicate the **top 10 priorities** by using the Number next to the 26 items.

The survey also ask for a written response to the following questions?

What do you like most about Iliamna?

What do you like least about Iliamna?

## Top Priorities of the Community of Iliamna

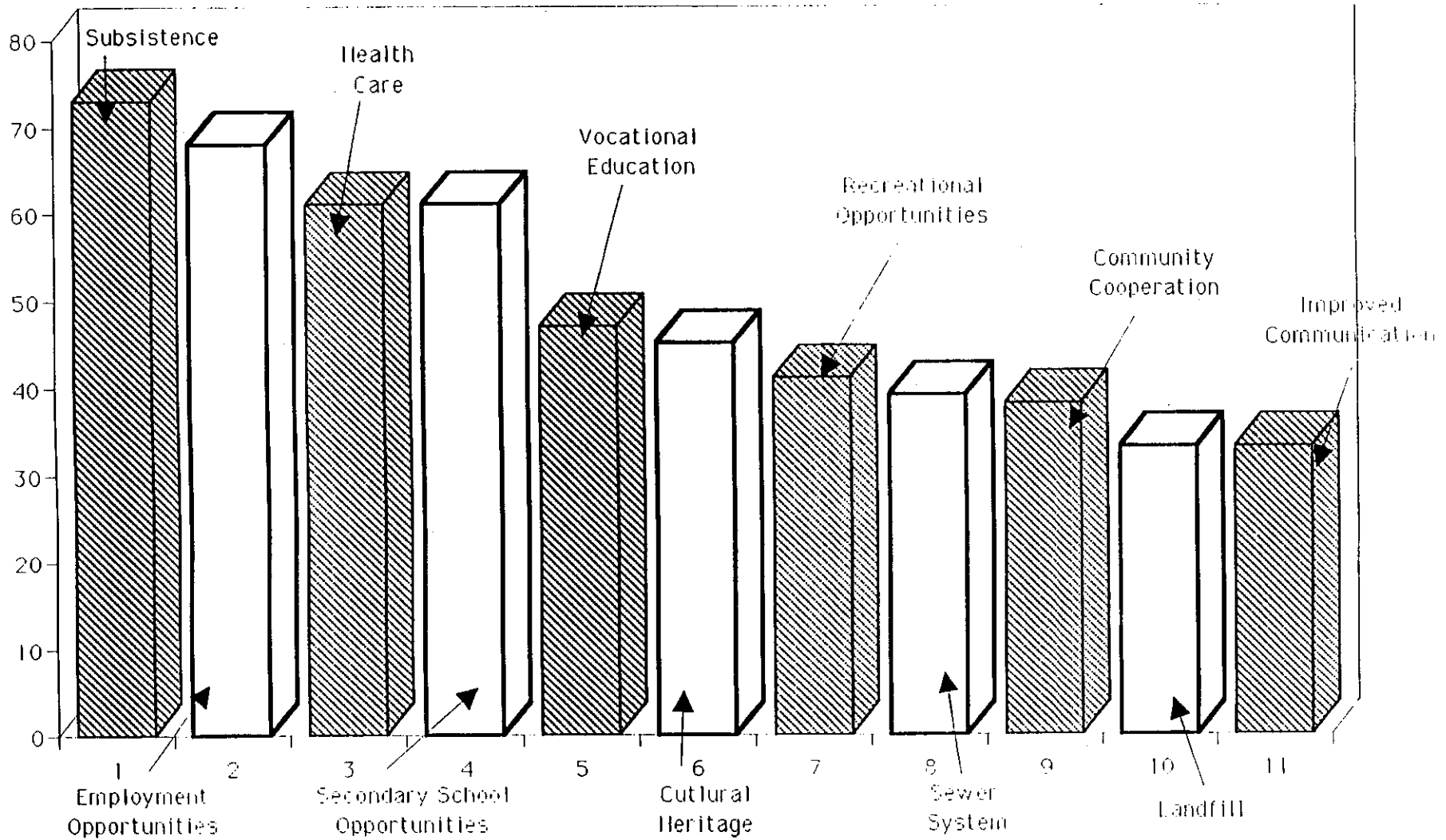



## Iliamna Survey

### Question 27 responses.

1. Communication and Cooperation.
2. Getting Tazimna hydro on line.
3. Wholesale store like Costco or Price Savers.
4. Pioneer home for Elder natives.
5. Community support of villages around lake for Tazimna hydro power.
6. Protect the largest spawning lake of salmon in the world.
7. Elders home for lake community residents.
8. We need an organization other than the tribal council to manage State and Federal assistance.
9. Development of a sense of community by all residents with the goal of putting the best interests of the future of the community as a whole first and the interests of the individual, group or business second.
10. For the white people to treat the native people with more respect and to remember if it was their land they wouldn't share like the Native people do.
11. Walking and biking path.
12. Community paper and news.

### Part III responses. Like best about Iliamna

1. It's isolation from the big city. It's freedom.
2. Quality of life.
3. The people, the beauty, semi-remoteness of her location and abundant natural resources.
4. Besides one of the last beautiful place in Alaska, crime free and very little drug or alcohol problems.
5. The friendly and helpful people. a good educational school for our kids.
6. The chance to get out and enjoy life as a subsistence way of life. The friendly and helpful people.
7. Good school, good people, no crime as of yet, life is enjoyable.
8. The natural environment.
9. The closeness of the community, especially in times of need but yet the separation to live individual lifestyles.

10. The true freedom that we enjoy here. Not being crowded and overrun with people. Good clean air to breathe. Good hunting and fishing to enjoy. A beautiful country to raise children in.
11. That people can trust others and their children can play and not worry about someone chasing them off their land.
12. The people.
13. Quiet and no crime.

**Part IV responses. Like least about Iliamna.**

1. No governmental organization. Too much village politics. Successful businesses, especially lodges, not doing their part in the community.
2. The fact that the non-natives want access to all the property. if the tables were reversed, they would prohibit everyone from using the land.
3. Probably some of the weather systems. it would be better if more pride was taken the appearance of residential areas.
4. Exploiters taking the money and running, and no community center for get togethers.
5. No recreational or cultural games available- our kids should be learning of their proud heritage.
6. There are no community activities. only a few brave and well-meaning people try to do something. the rest don't care.
7. No community center for local people during holidays, Newhalen school is open but let's build one that can sustain some pride by the people.
8. The impact on our lives resulting from lodge operations during sports fishing and hunting seasons.
9. Not having a community wide water and sewer system. lack of support and encouragement of local businesses and personal endeavors.
10. The typical small town scenario where the people who do the least bitch the most about the people who are doing the most for the community.
11. The attitude change of local people as summer comes and the lodges open.
12. That the lodge people come in don't hire any local people and have guides from the outside and teachers come here and have nothing to do with the local people.
13. This is not a community. no improvements, such as the dump area.
14. Access to the surrounding villages is not enough.

**Question #1: Having a community wide water system.**

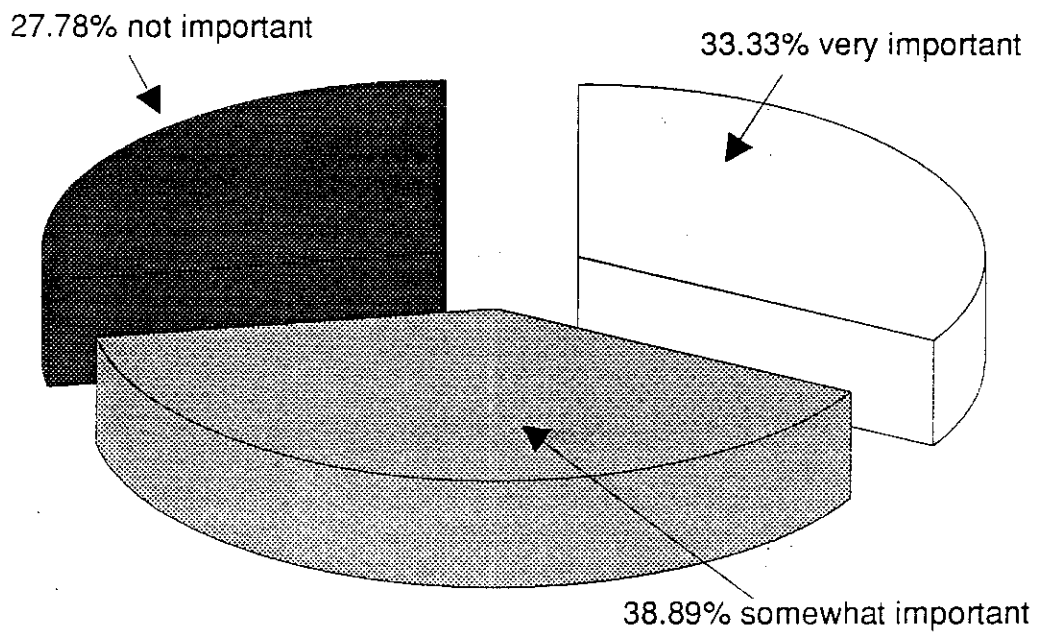

**Question: 2 Having a community wide sewer system.**

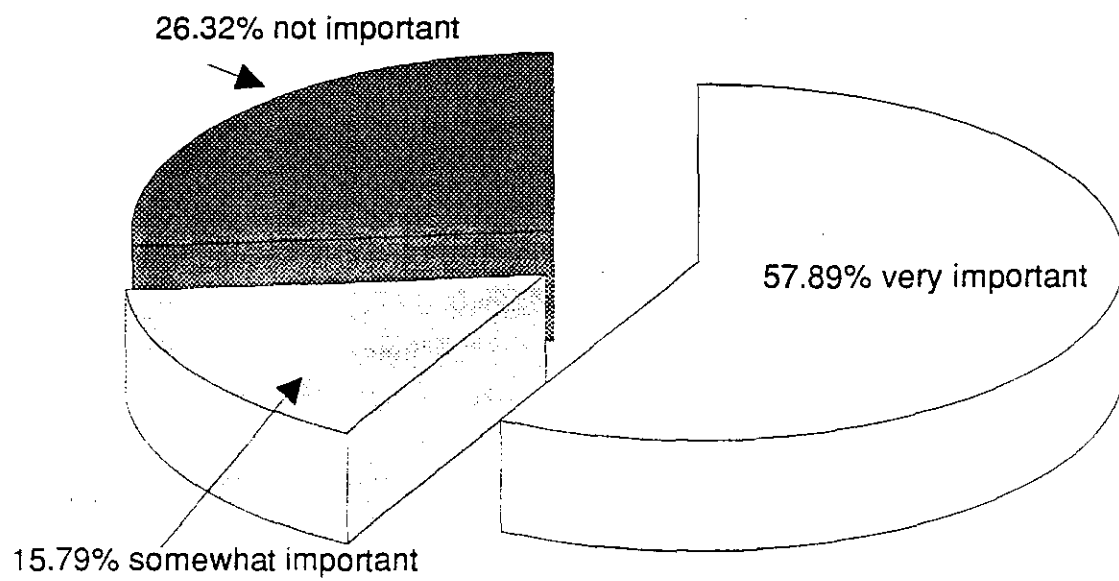

**Question #3: Having better employment opportunities for young people.**

15.79% somewhat important

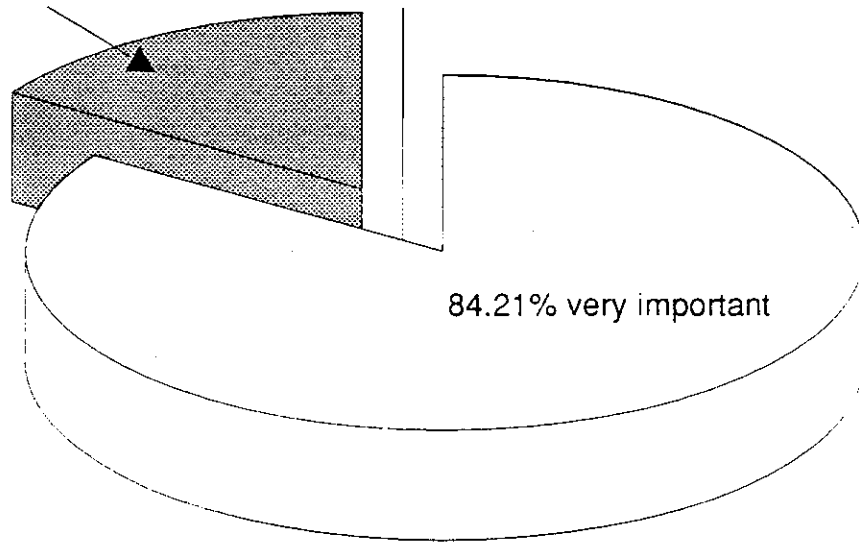

84.21% very important

**Question #4: Maintaining subsistence opportunities for residents.**

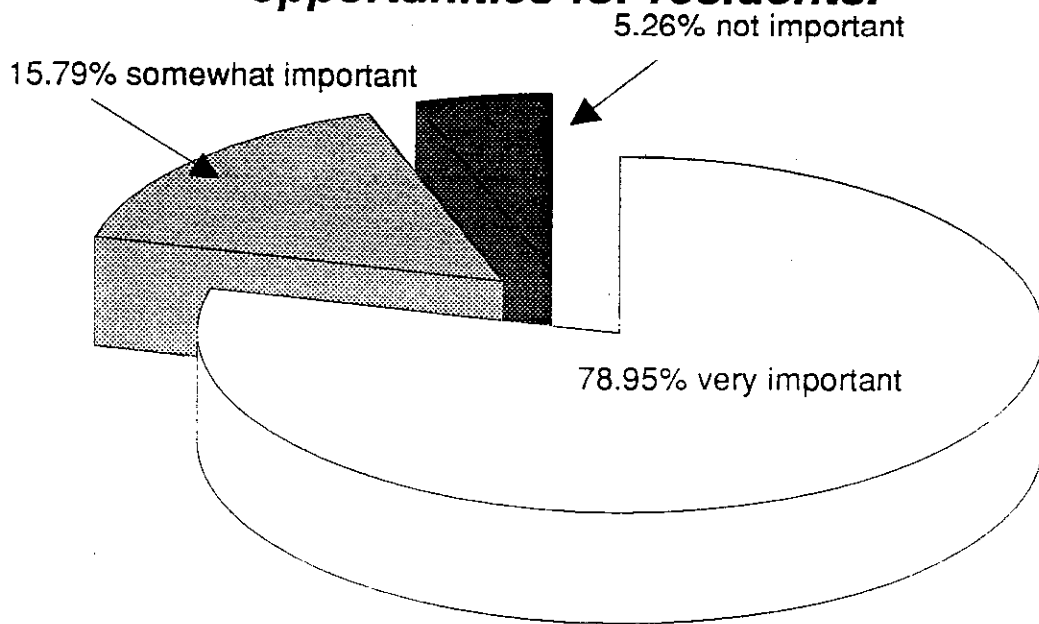

**Question #5: Improving health care facilities and services.**

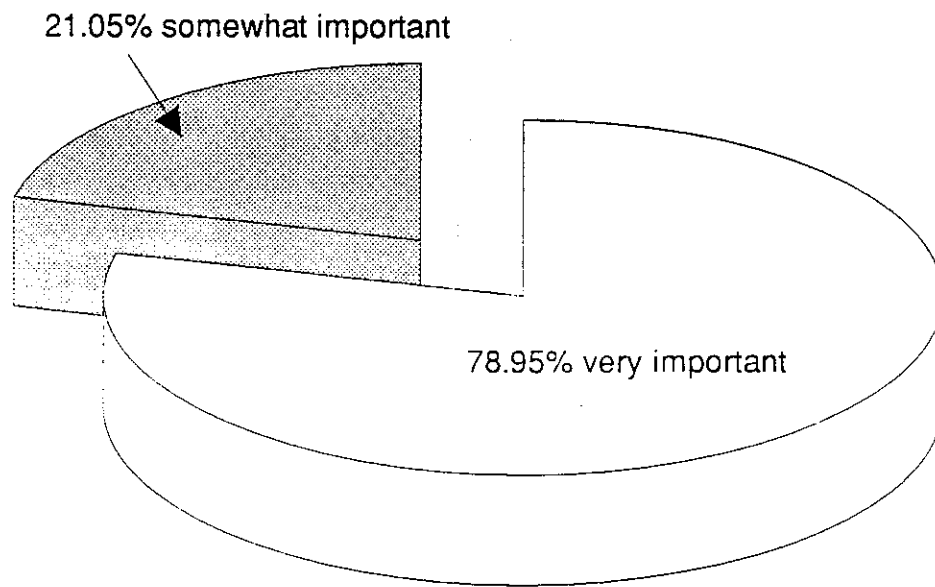

**Question # 6: Having better educational opportunities in secondary schooling**

15.79% somewhat important

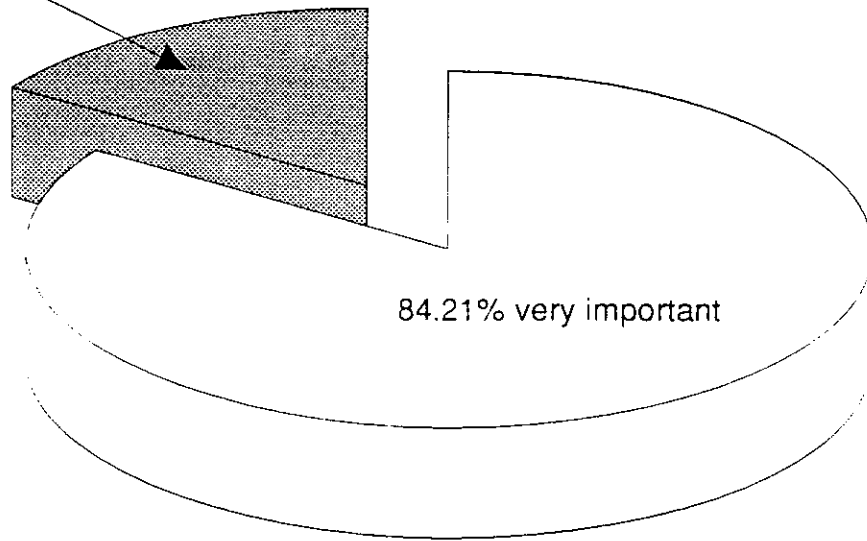

84.21% very important

**Question #7: Having better educational opportunities in vocational schooling.**

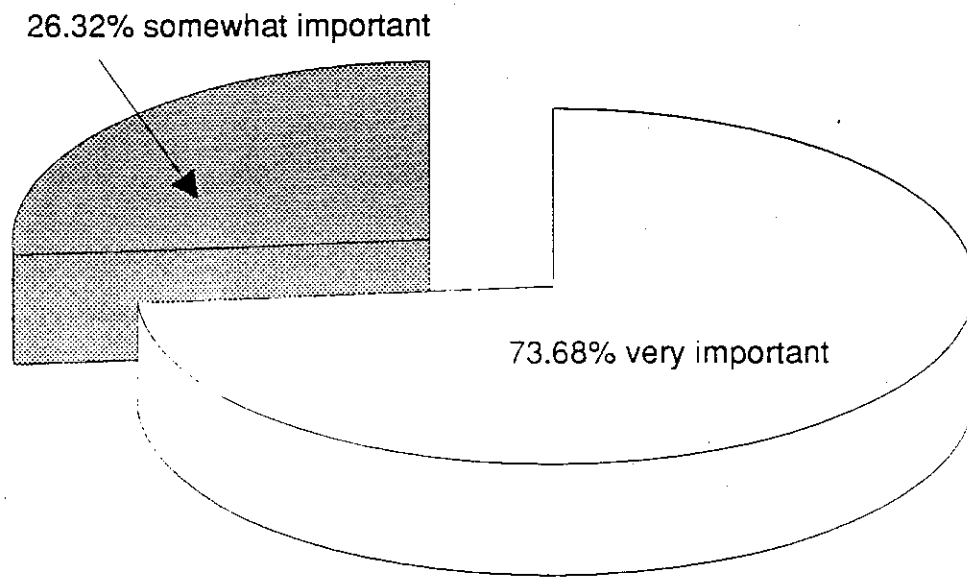

**Question #8: Having better facilities for disposing of garbage, such as landfills.**

42.11% somewhat important

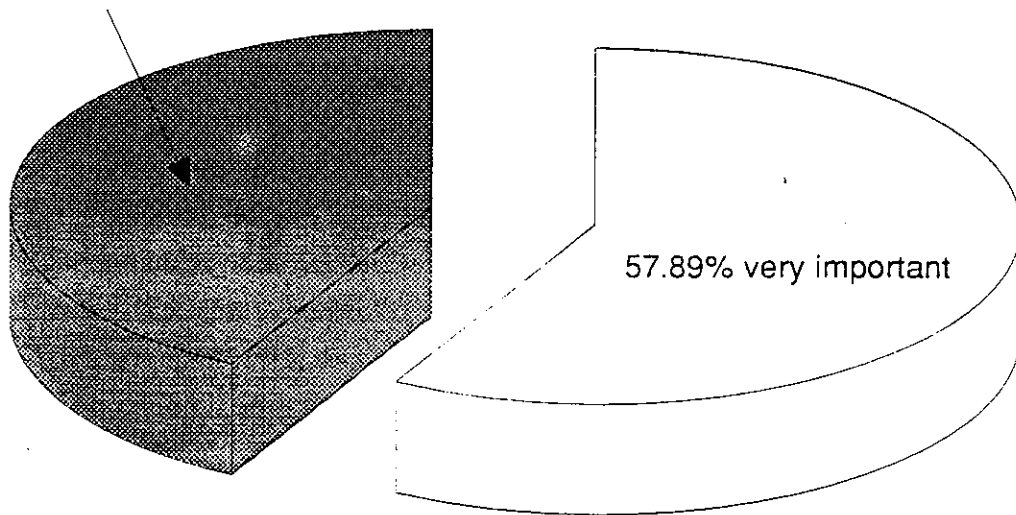

**Question #9: Having a community library.**

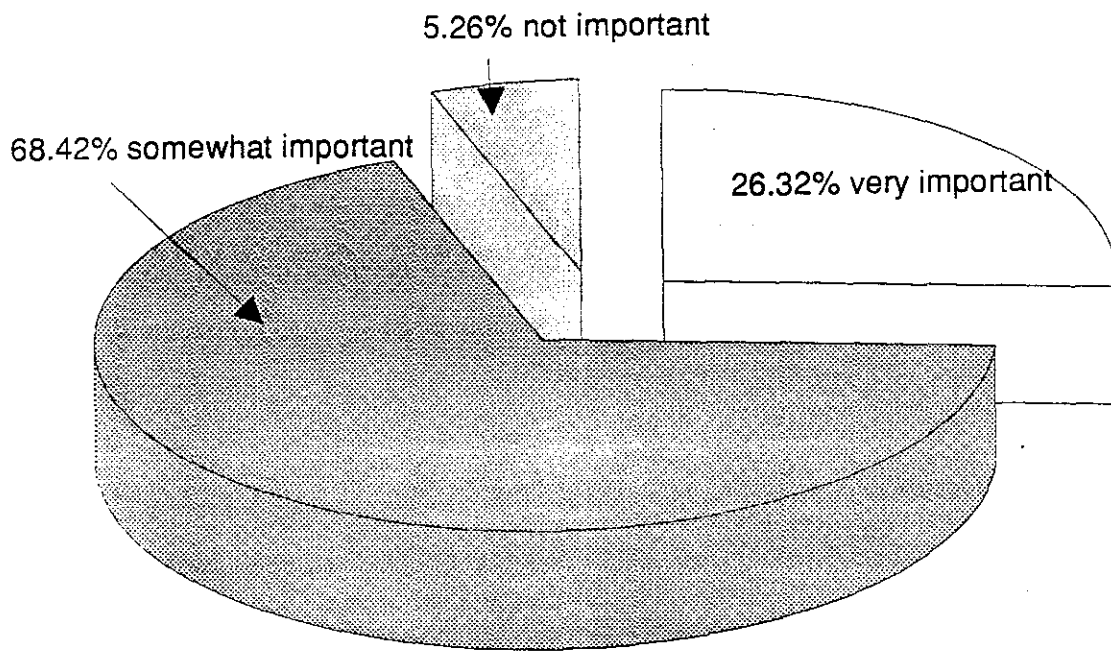

**Question #10: Having a way to handle the large number of seasonal sport fishermen and hunters.**

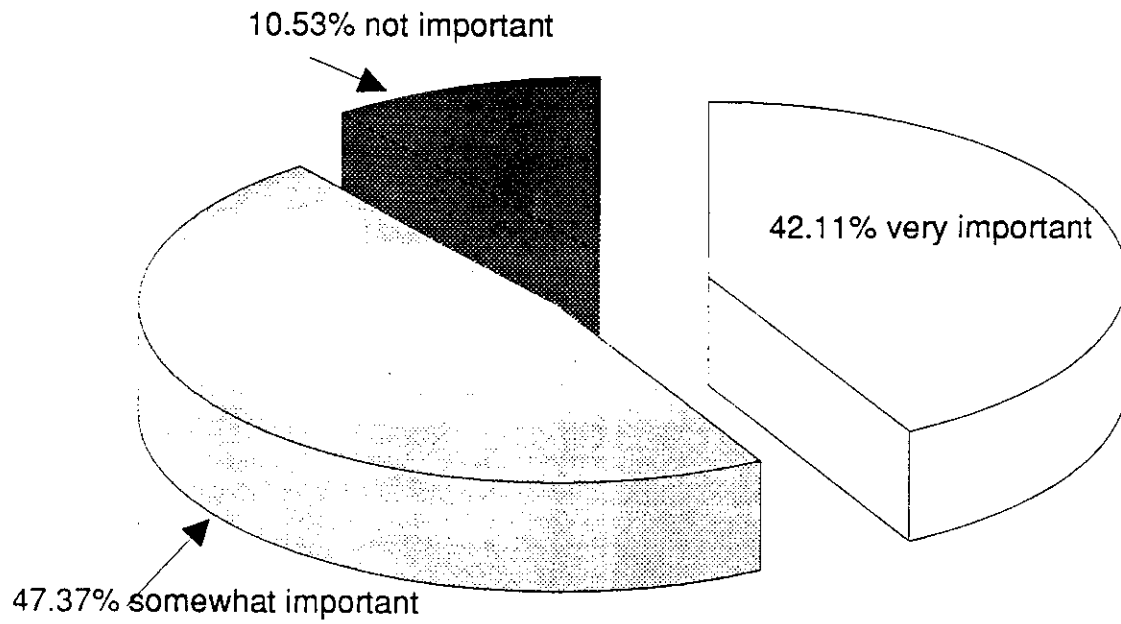

**Question #11: Having designated camping areas for visitors.**

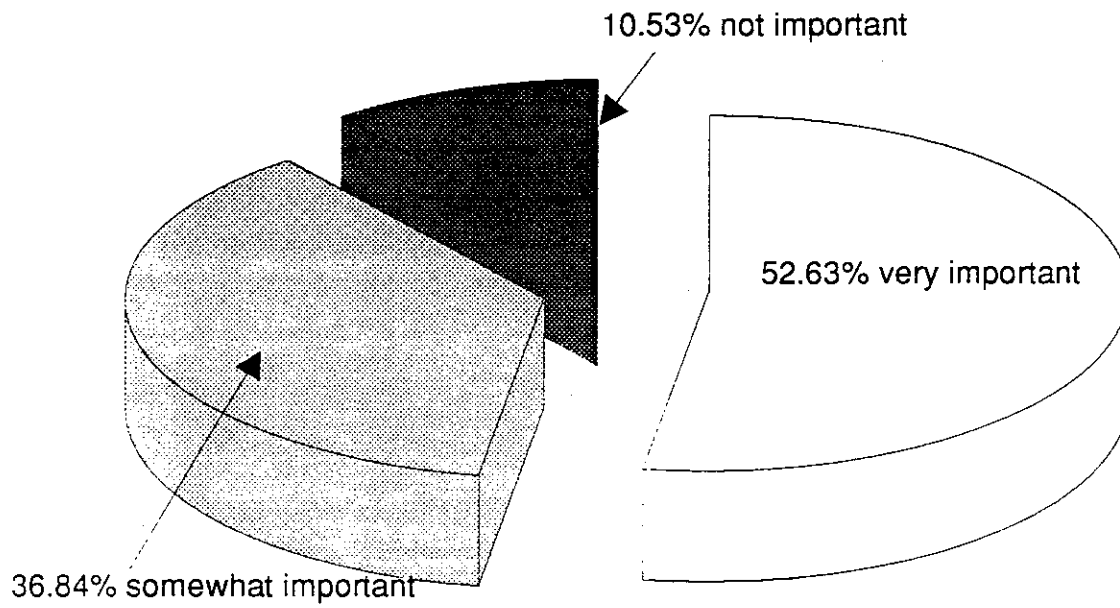

**Question #12: Having recreational opportunities for residents and youth.**

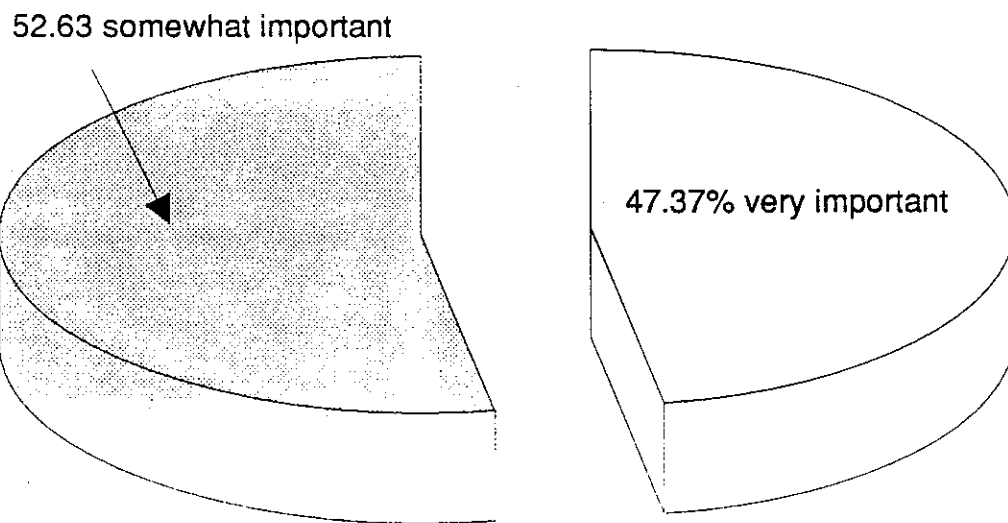

**Question #13: Better disposal of hazardous waste.**

47.37% somewhat important

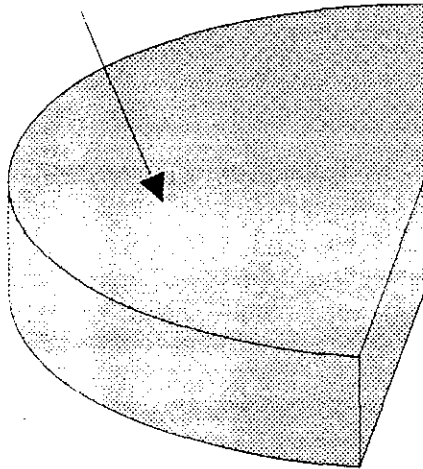

52.63% very important

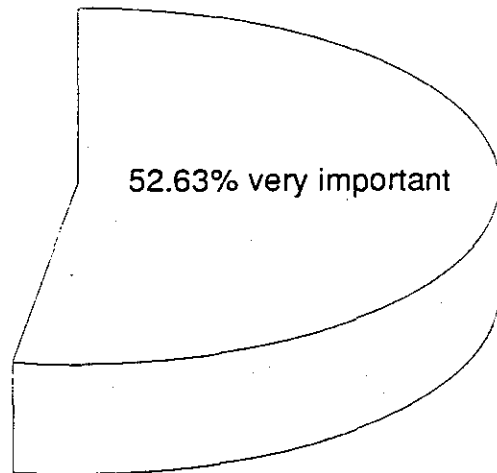

**Question # 14: Recycling of disposable products.**

63.16% somewhat important

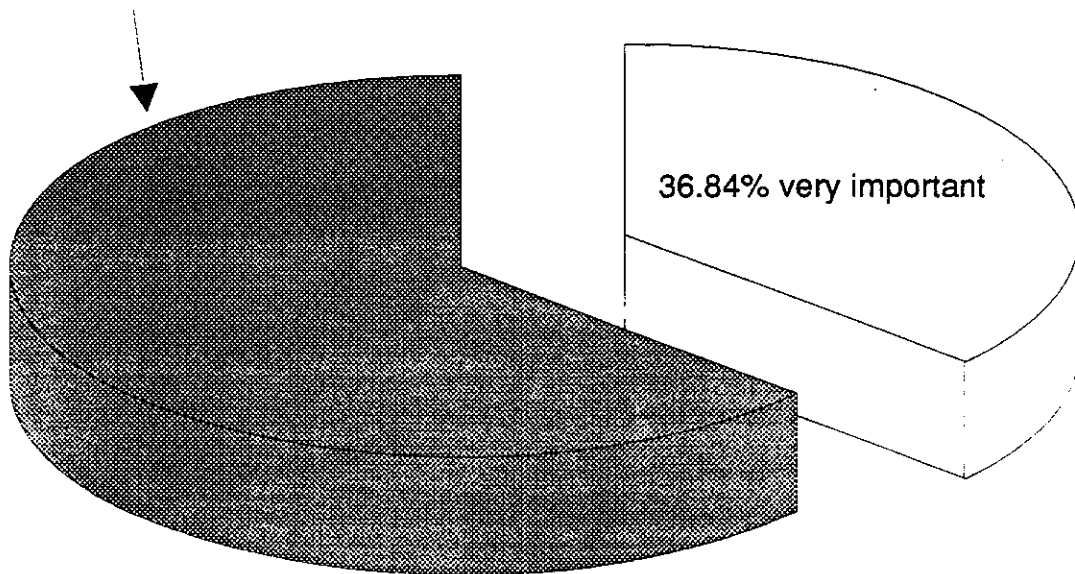

**Question #15: Maintaining the existing quality of life.**

29.41% somewhat important

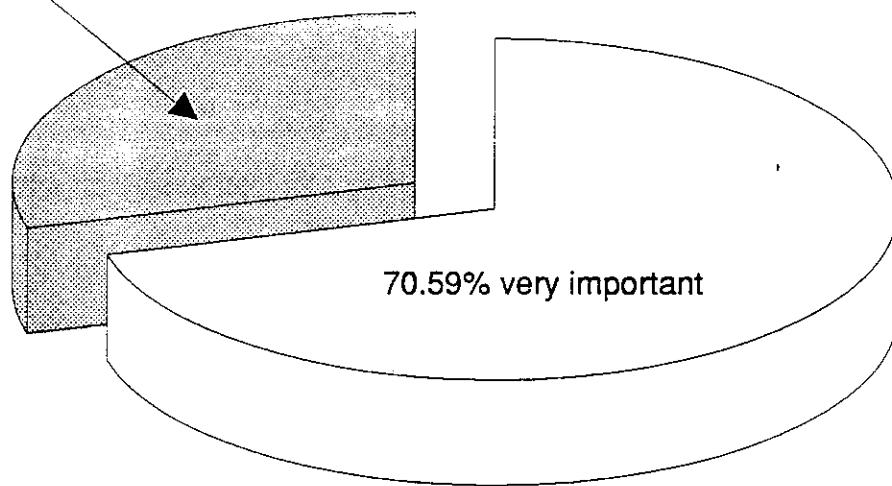

70.59% very important

**Question #16: Having a subregional clinic  
in Iliamna.**

50% somewhat important

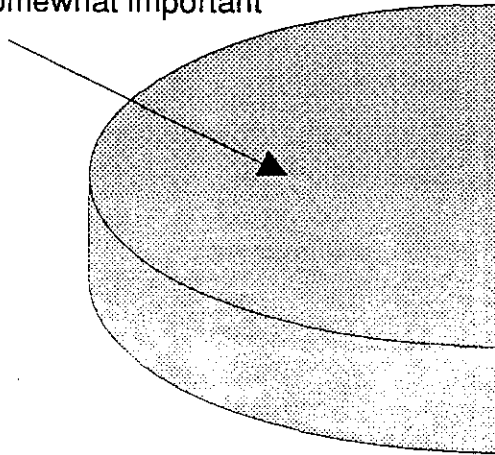

50% very important

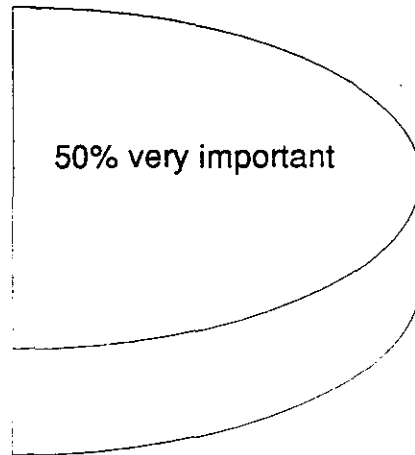

**Question # 17: Controlling the rate of growth in the community.**

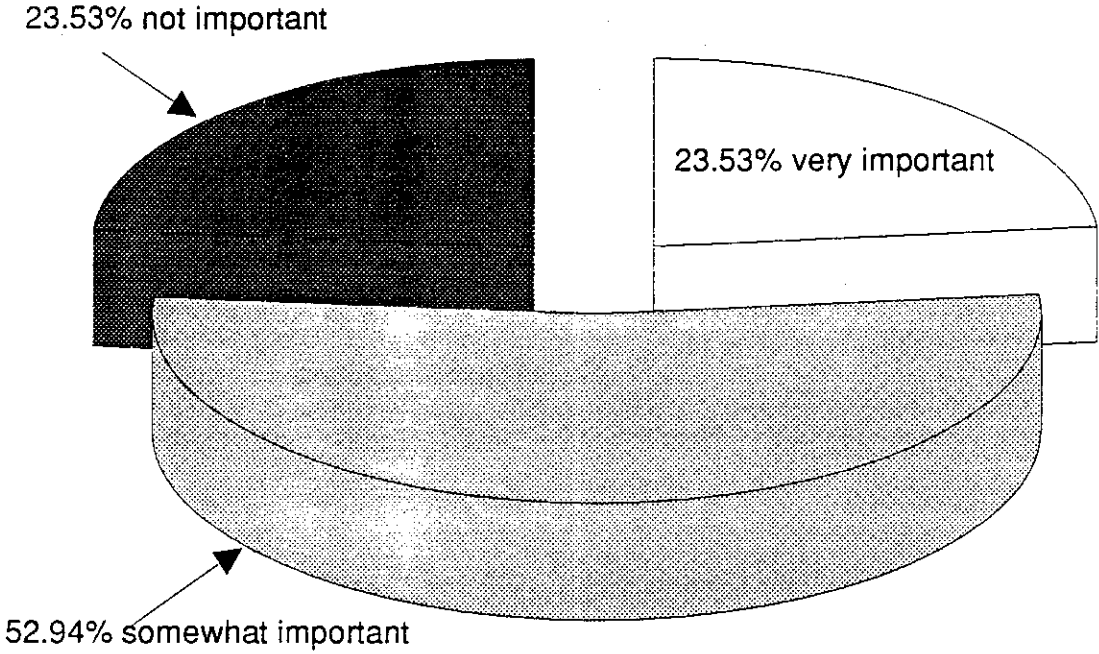

**Question #18: Better planning of future development of the community.**

22.22% somewhat important

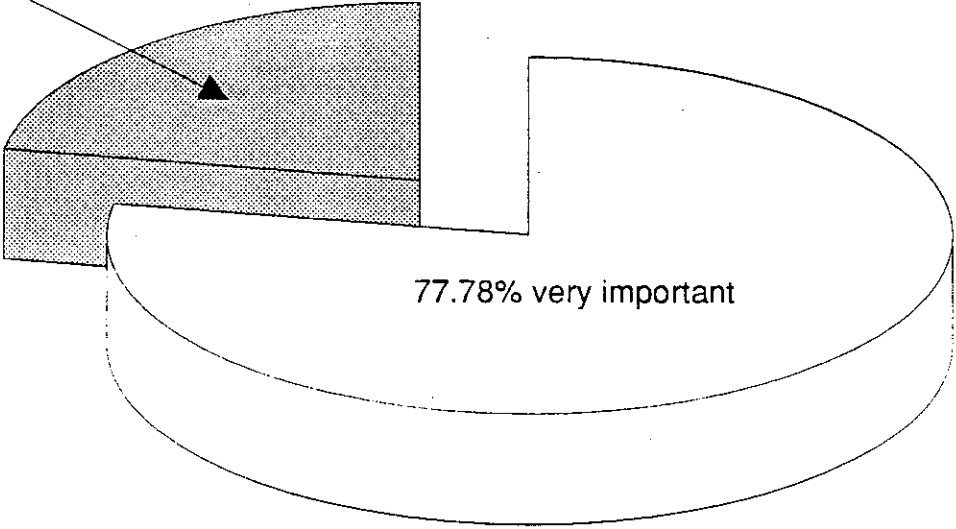

77.78% very important

**Question #19: Having a functional day care in the community.**

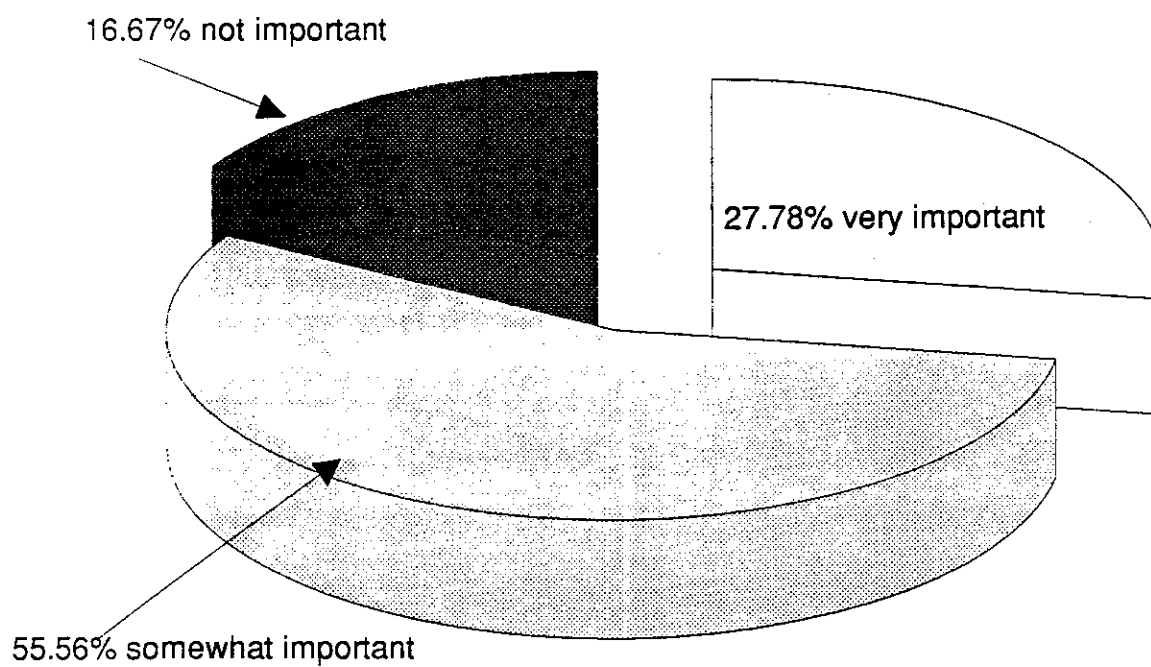

**Question # 20: Having no taxes for residents or businesses.**

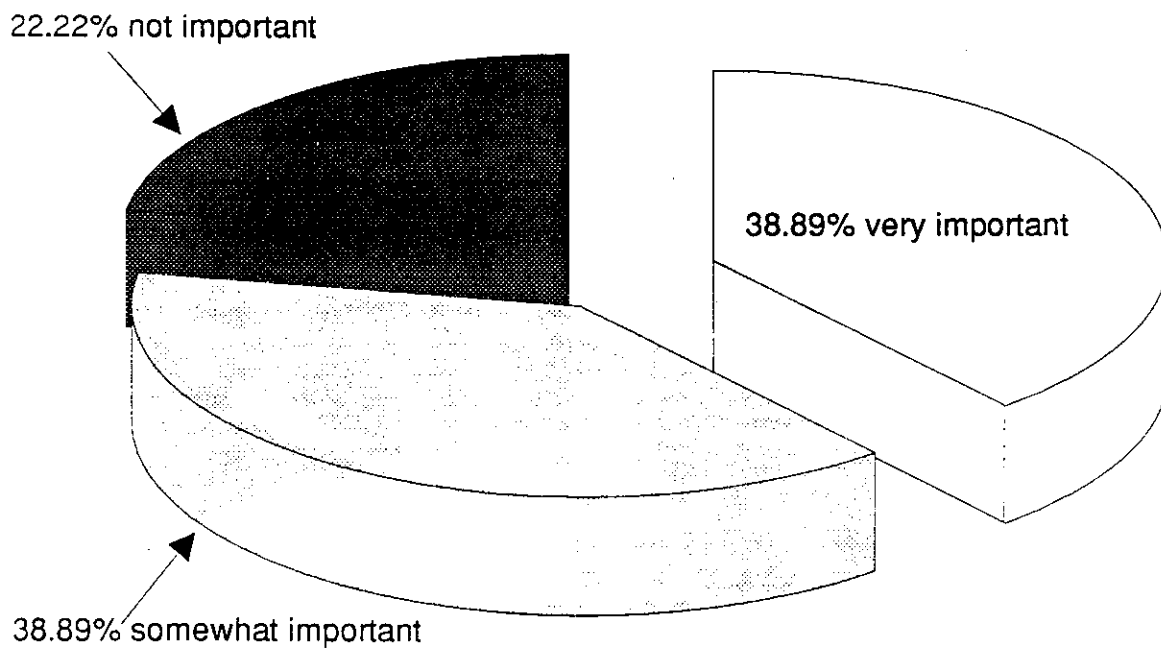

**Question #21: Improved communication  
between the cultural segments of the  
community.**

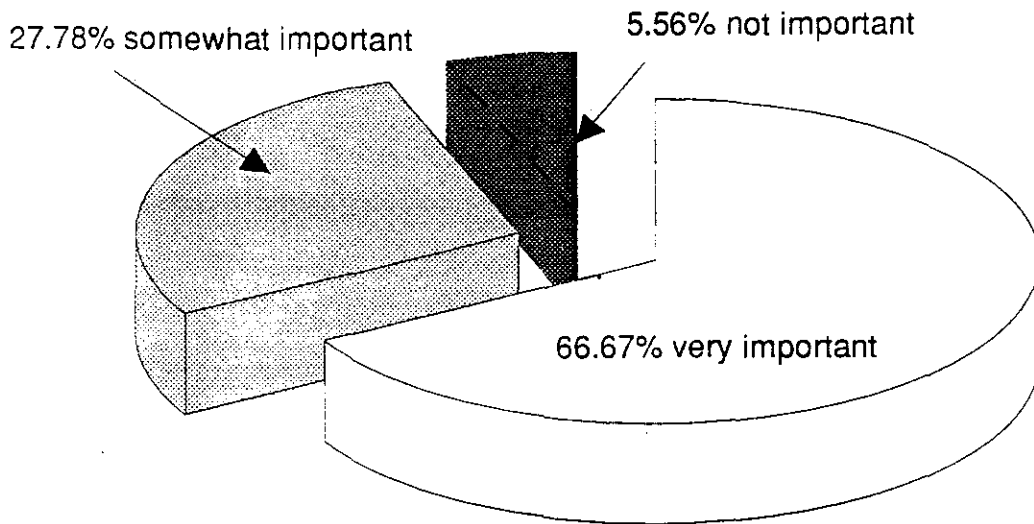

**Question #22: Regaining the cultural heritage of the Native culture.**

5.26% not important

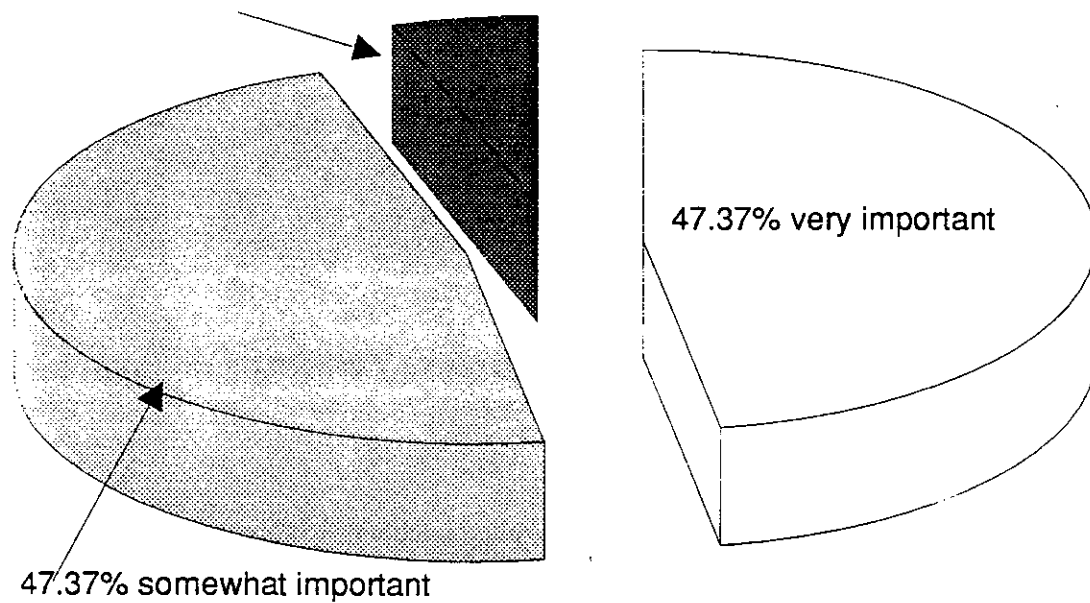

**Question #23: Having the community work together better on future issues.**

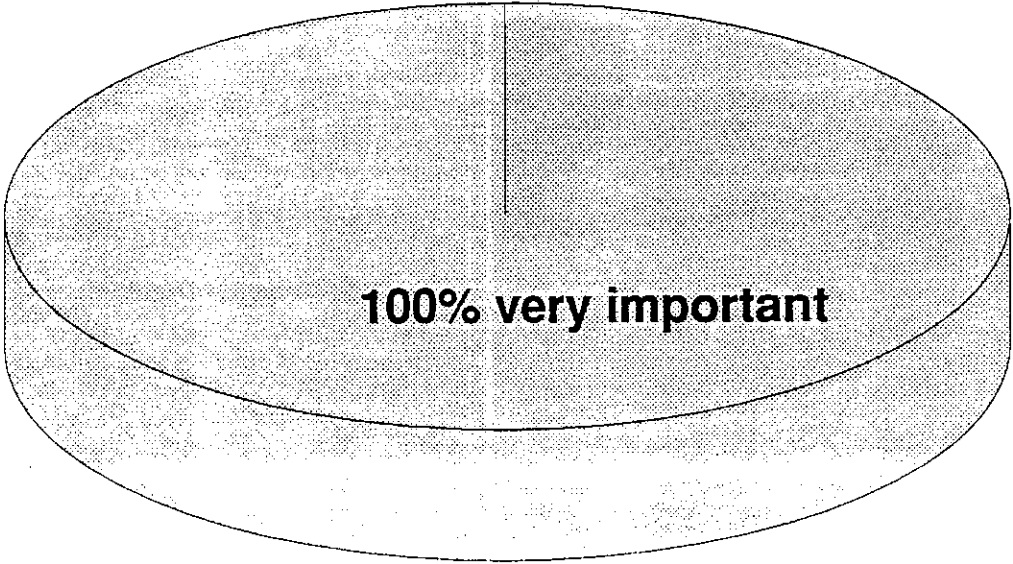

**Question #24: Community support for local businesses.**

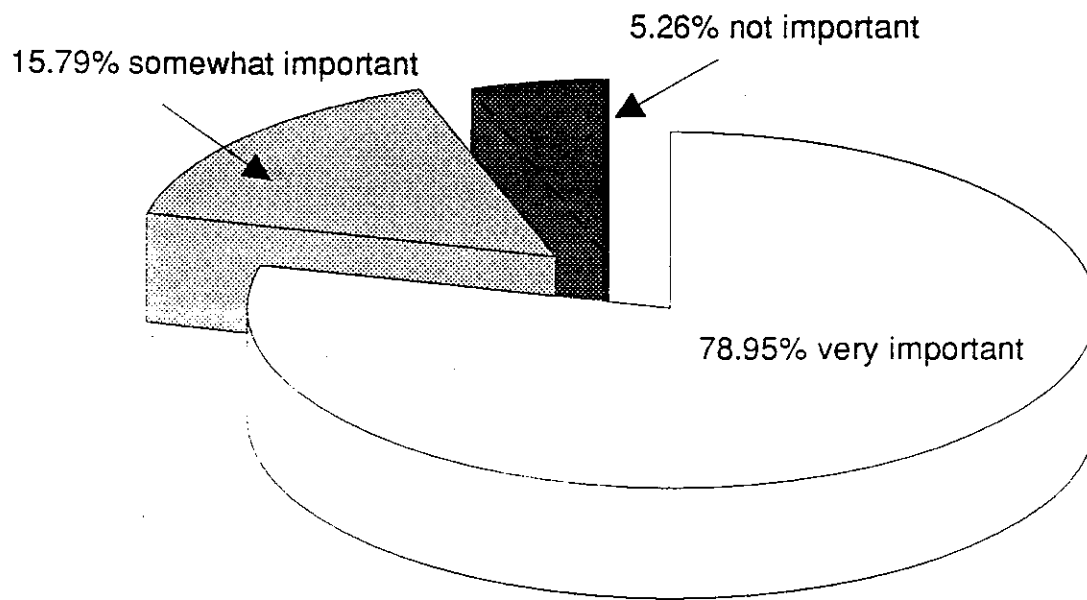

**Question #25: Encouraging new business opportunities.**

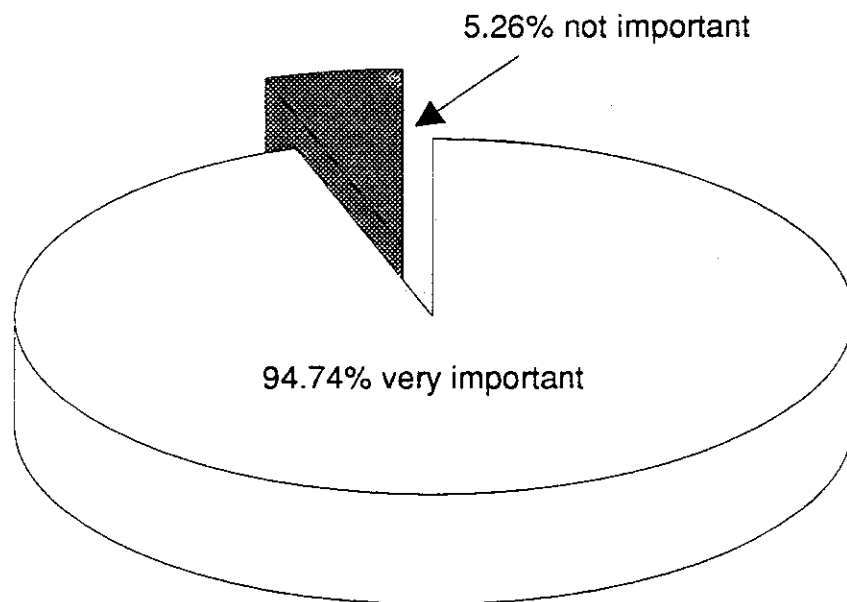

**Question #26: Having park areas available for community use.**

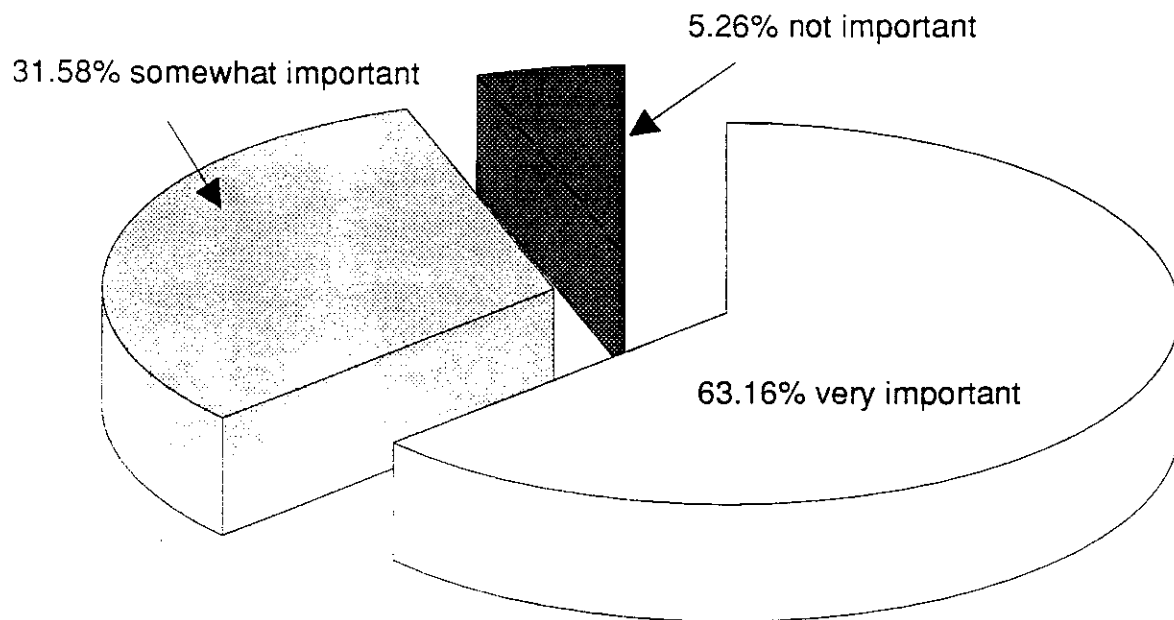

**Iliamna Community Meeting**

**March 31 - April 1, 1992**

## Iliamna's Vision Agenda

Tuesday, March 31, 1992

7:00 PM Welcome

Introductions

Review Process and Last Meeting

Review of Survey Results

Exercise: Family Feud Quiz

Survey Results Discussion

Break

8:15 PM Iliamna's Vision For The Future

Group Discussion

Report of Groups

Consensus Building

Break

9:00 PM Goals To Reach Our Vision

Group Discussion By Categories Of Goals

Economics, Education, Lifestyle, Health and Well

Being, Community Facilities, Governance,

Environment, and Community.

Report of Groups

Consensus Building

10:00 PM Adjourn until Wednesday

# Iliamna's Vision Agenda

**Wednesday, April 1, 1992**

- 7:00 PM      Welcome
  
- Review Process
- Yesterday's Progress - Vision and Goals
  
- Objectives To Reach Goals
- Group Discussion
- Group Report
  
- 8:00 PM      Break
  
- Barriers To Reach Objectives
- Group Discussion
- Group Report
  
- 9:00 PM      Action Plans
- Using Community Strengths To Overcome Barriers
  
- Group Discussion
- Group Report
  
- 10:30 PM     Wrap up.

## Iliamna's Vision Of The Future

Where do we want to be in 10 years as a community? What would we like Iliamna to be known as in the next 10 years?

These are the sort of questions that lead to a "vision" for the community. It must be a shared vision not just a person's or small group's idea.

To begin the development of a community vision, first ask yourself the above questions. Then as a small group share your statements. Discuss each person's ideas and combine the ideas as much as possible into a statement. It is not necessary to have only one statement but it is necessary to have agreement with all the statements.

An example of a vision statement: "In 10 years, I want a community of doers who work together for the things our community values."

or "In 10 years I want Iliamna to be known as a healthy, beautiful place where families get along and work together for a better community."

Each group should elect a recorder to put the results of the group's discussion on the flip charts provided. These will be used in the presentation to the whole.

Now let's share the individual group's statements among the other groups. Each group will appoint a spokesperson to go over the statements and expressed feelings of the group. Other members of that group should offer their thoughts as well and don't leave all the responsibility on the spokesperson's shoulders.

After the presentations of each group, can we combine statements without losing anything? An open discussion of the whole meeting to arrive at a statement or small group of statements that can be called a "vision" for the community.

## **Achieving Our Vision Goals Setting**

Its not enough to just have a vision of where we want to go. We need to find a way to make it a reality. The first step to that vision is to establish goals that can be obtained and move us closer to the vision.

Using the same process as we did with the vision statements, let's discuss goals. But first, what is the difference between a vision and a goal. Don't get hung up on trying to make a difference. It is more a matter a how specific a statement is. Vision is more general and maybe not easy to see how to accomplish it. A goal should be more specific and there should be some ideas on how to work towards it.

Example of a goal: "Iliamna should work towards more participation in community decisions by community members."

or "Iliamna should maintain the quality of the natural environment that we all treasure."

To begin the development of community goals, first identify some yourself. Then as a small group share your statements. Discuss each person's ideas and combine the ideas as much as possible into a statement. A series of goals would be expected in each of the main categories of community concerns. For example, can we categorize the main areas of concern into: "Economics, Education, Lifestyle, Health and Well Being, Community Facilities, Governance, Environment, and Community." If not can we think of what kind of goals would relate to the community issues and vision?

Each group should elect a recorder to put the results of the group's discussion on the flip charts provided. These will be used in the presentation to the whole.

Now let's share the individual group's statements among the other groups. Each group will appoint a spokesperson to go over the statements and expressed feelings of the group.

After the presentations of each group, can we combine statements without losing anything? An open discussion of the whole meeting to arrive at goal statements.

## **Objectives Another Step Towards Action**

The next step toward our vision is to establish objectives. Objectives build from our goals and serve as the short term results we want to see from the community's action. Objectives should relate to our goals and be doable. Don't worry about the difference between goals and objectives. Objectives are doable in the shorter time than the goals.

By now you know the process we are going to use. To begin the development of community objectives, first identify some yourself. Then as a small group share your statements. Discuss each person's ideas and combine the ideas as much as possible into a statement. A series of objectives would be expected in each of the goals identified.

Each group should elect a recorder to put the results of the group's discussion on the flip charts provided. These will be used in the presentation to the whole.

Now let's share the individual group's statements among the other groups. Each group will appoint a spokesperson to go over the statements and expressed feelings of the group.

After the presentations of each group, can we combine statements without losing anything? An open discussion of the whole meeting to arrive at objectives.

## **Barriers/Strengths**

Now we know where we need to be. What issues, problems and barriers do we need to overcome to achieve it? What resources or strengths does our community have to overcome these barriers?

Once again lets discuss this in our now familiar group discussion process. However, the community survey should provide us with some ideas on what our community sees as barriers and strengths.

Each individual and then each group identify the strengths and the barriers.

Example: A barrier to achieving cooperation and working together as a community, is the lack of get-togethers, geographic separation of the community.

Example: A strength of our community in achieving better health care is our good communication and transportation facilities that allow us to get help relatively quickly.

Each group should elect a recorder to put the results of the group's discussion on the flip charts provided. These will be used in the presentation to the whole.

Now let's share the individual group's statements among the other groups. Each group will appoint a spokesperson to go over the statements and expressed feelings of the group.

After the presentations of each group, can we combine statements without losing anything? An open discussion of the whole meeting to arrive at agreement on barriers and strengths.

## **Action Plan**

We know where we need to be and what stands in our way and what we can consider a resource. Let's discuss what the community can do now and in the near future to achieve objectives, goals and ultimately our vision.

Each group should elect a recorder to put the results of the group's discussion on the flip charts provided. These will be used in the presentation to the whole.

Now let's share the individual group's statements among the other groups. Each group will appoint a spokesperson to go over the statements and proposed action plan of the group.

After the presentations of each group, can we add the whole group's ideas to the action plan?

**Iliamna Community Meeting**

**April 17, 1992**

**Iliamna Community Meeting  
April 17, 1992**

**Agenda**

**Review**

Where are we?  
Where are we going?  
Review materials.

**Exercise**

Paper tearing

Break into groups -- assign categories for goal statements

Group reports on goals

– discussion/additions

– final statements

Review "Health" Process / Action Plan

– Goal statement

– Strengths

– Barriers

– ACTION PLAN

Identify objectives to be developed into Action Plans

– Discussions/development of responses

## Iliamna's Vision

Through individuals working together for a better community, Iliamna will maintain the quality of life where residents and visitors will respect the people, land, resources and culture.

The following is a summary of the results of each work group's report to the meeting participants.

### Goal

#### **Lifestyle**

Maintain the unique, wholesome quality of life associated with a small rural Alaska community without urban problems

### Goal

#### **Health**

At a minimum maintain and improve existing health care by upgrading existing clinic and equipment and continued training of Health Aides and volunteers.

### Goal

#### **Governance**

Keep informed on the issues and proceed as necessary.

## Goal

### **Education**

Continue to improve the educational facilities and opportunities for youth and adults.

OJT

## Goal

### **Community**

Maintain the friendliness and neighborliness of the community. Encourage active participation by all members of the community. Improve relations and communications between residents and seasonal business operators.

## Goal

### **Facilities**

To have facilities that improve the quality of life that are financially supportable, cost-effective and based on existing needs and the foreseeable future.

## Goal

### **Economy**

Encourage local residents to become service providers (businesses) to tourists. Encourage lodges to hire local residents and use local services (businesses).

## Goal

### **Economy**

Residents need access to summer economic opportunities (jobs) in the lodges. Encourage residents to provide services to lodges.

## **Action**

### **Economy**

Initial meetings with lodges and INL, tribal council, Newhalen and Iliamna residents to promote local hire next year.

Recognize lodges contributions.

Get it organized early.

Identify sources of dollars for training or enterprises.

## **Action**

### **Facilities**

14(c)(3) settlement — identify sites

Identify costs — Operation and Maintenance (O&M) of existing and proposed facilities.

Landfill – O&M plan  
Sewer – site for lagoon  
Parks and recreational area  
Future public building land  
Elders home

Respect for INL and APC land.

## **Action**

### **Community**

Meeting with lodges

Winter have community functions

Inform campers and sports fishermen of community services and how to respect community concerns.

## **Action**

### **Education**

Use OJT.

Encourage use of Local Action School Council (LASC).

Identify employment and training needs for community.

Identify current and future businesses and facilities needed by the community.

Vocational education – small engine.

## **Action**

### **Lifestyle**

Keep trooper here.

Support local subsistence activity.

Support subsistence concept at federal, state and local level.

Take responsibility for keeping area clean.

Have community clean up picnic. Coordinate with lodges.

No toleration for "drug" dealing or alcohol trafficking.

Airport sign.

## **Action**

### **Governance**

Don't rock the boat.

Issue will be dealt with when it becomes an Issue.

Keep informed on issues.

Keep communication with Newhalen.

Keep informed on Borough actions.

Iliamna and Newhalen need healing.

Need "Iliamna" to develop sense of community focus.

**Iliamna Community Meeting**

**November 19, 1992**

# ILIAMNA COMMUNITY MEETING

November 19, 1992

## Agenda

Ice Breaker Exercise

What can you remember?

Review

Review what has transpired in visioning sessions

Review actions plans to see if changes are needed

Transition to ANCSA 14(c)(3) Process

## COMMUNITY MEETING

On November 19, 1992, the final community visioning meeting was held. Nine residents attended. The group reviewed the goals and action plans which were formulated in April. A few additions and modifications to the action plans were made.

A considerable amount of time was spent discussing how action plans can be implemented and who is going to do it. Participants agreed that there was a need for better communication between the village tribal council and other residents in the community. Better communications will be necessary if the action plans are to be effectively implemented.

The meeting participants decided that there should be a community-wide meeting in late January 1993 to present the final visioning report. It was decided that this meeting would be in conjunction with a pot luck dinner.

The last item discussed was how to proceed with the ANCSA 14(c)(3) identification process. It was decided that a 14(c)(3) committee should be formed consisting of 2 members from the village corporation, 2 members from the village council and 3 members from the community at large. This process was made contingent on village corporation approval. This committee would work with the Municipal Land Trustee Program in DCRA to identify potential ANCSA 14(c)(3) conveyances.

# **Iliamna's Future**

**Final Report to the Community**

**December 1992**

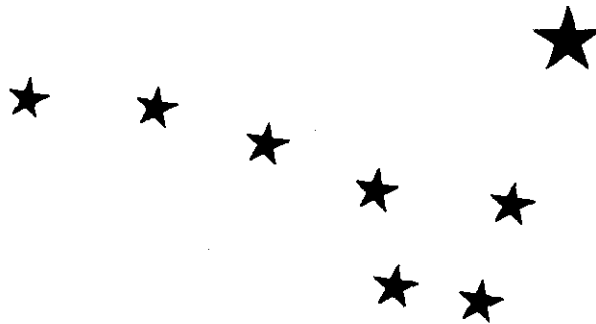

**The following individuals participated in one or more community meetings that resulted in this report.**

Bob Arce  
Sue Arce  
Bert Foss  
Tim LaPorte  
Sally Moses-Baechler  
David M. Parks  
Elia Anelon  
Myrtle Anelon  
Ethel Adcox  
John Adcox  
Maria Anelon  
Harvey Anelon  
David Parks  
Harry Ricci  
Robert Drew  
Edna Foss  
James Drew  
Trig Olson  
Hans Roehlet  
John W. Johnson  
Lorene A. Arce  
John Adcox  
Richard Harkness  
Norm Aaberg  
Laura Aaberg

The State of Alaska, Department of Community and Regional Affairs, Municipal and Regional Assistance Division, facilitated the community meetings and produced this report at the request of the Iliamna residents.



## Iliamna's Future Goals and Future Actions

The residents of Iliamna have a responsibility to the community. Last Spring a group of residents demonstrated their willingness to accept this responsibility by working hard to identify a vision to guide the future of Iliamna. They attended community meetings in the evenings and on weekends and talked among themselves about the future and goals the community should work toward. They also discussed actions that could be taken by residents to improve the community. This is a summary of the results of their efforts.

The effort began with community meetings in February 1992 and continued through mid April 1992. Everyone was welcome to participate in those meetings. Notices were sent to each post office box holder and also posted in public places. During this period, every Iliamna box holder also received a questionnaire asking for their opinions on Iliamna's future. The results of this survey were reviewed and considered during the community meetings.<sup>1</sup>

What were the products of these efforts? The first major product of the community meetings was a goal statement for the community. That goal was developed in response to a question:

What should the goal of the community of Iliamna be for the next 10 years?

The residents that participated last Spring said, "**Through individuals working together for a better community, Iliamna will maintain the quality of life, where residents and visitors respect the people, land, resources and cultures of the community.**"

<sup>1</sup>The responses to the survey are available from the village council and from those that attended any of the community meetings.

How can the community achieve this vision of the future? As a result of the meetings last Spring, seven issues were identified that needed action. These were:

- ✓ Health
- ✓ Education
- ✓ Economy
- ✓ Lifestyle
- ✓ Governance
- ✓ Community
- ✓ Facilities.

For each of these issues, a goal was identified and actions to achieve the goal were outlined. The following is a summary of what the residents wanted.

# HEALTH

## GOAL STATEMENT

The residents of Iliamna want to maintain and improve existing health care services by upgrading the existing clinic and equipment and continuing the training of Health Aides and community health care volunteers.

## ACTION PLAN

To achieve the Health goal, the residents of Iliamna have identified the following actions:

- ★ Organize a community effort to inform lodge owners and seasonal businesses of the services provided by the clinic and the importance of these services to their clients.
- ★ Seek contributions from businesses and residents for better equipment for the clinic.
- ★ Encourage continued training for the health aides and community volunteers.
- ★ Establish programs for: Substance Abuse, AIDS Awareness, Suicide Prevention, and Planned Parenthood.

# EDUCATION

## GOAL STATEMENT

The residents of Iliamna want to improve educational facilities and opportunities for youths and adults.

## ACTION PLAN

To achieve the Education goal, the residents of Iliamna have identified the following actions:

- ★ Demonstrate the community's appreciation for the high caliber of educational services provided by the high school.
- ★ Seek out opportunities for vocational education in Iliamna.
- ★ Work with Bristol Bay Branch College to establish courses that may be offered to the Iliamna communities in Iliamna.

# ECONOMY

## GOAL STATEMENT

The residents of Iliamna want to provide for economic opportunities for residents and for the children who must now relocate elsewhere to find gainful employment.

## ACTION PLAN

To achieve the Economic goal, the residents of Iliamna have identified the following actions:

- ★ To support local businesses that provide employment opportunities for residents.
- ★ Encourage local residents to develop businesses that can provide employment opportunities and keep money in the community.
- ★ Develop communication between the lodges and the community that will result in more local people being hired for seasonal lodge jobs. This includes understanding what the lodges want from employees and what local residents can offer.
- ★ Encourage residents to look at lodge operations and clients as an economic opportunity.
- ★ Encourage continued support for the hydro-electric project.

# LIFESTYLE

## GOAL STATEMENT

The residents of Iliamna want to maintain the unique, wholesome qualities of life associated with small rural Alaska communities and avoid the problems of urban life.

## ACTION PLAN

To achieve the Lifestyle goal statement, the residents of Iliamna have identified the following actions:

- ★ Support local subsistence activities.
- ★ Seek support for the subsistence concept at the federal, state and local government level.
- ★ Take responsibility to keep the community clean.
- ★ Community and local businesses sponsor a clean-up day and picnic each spring.
- ★ No toleration for "drug" dealing or alcohol trafficking.

# GOVERNANCE

## GOAL STATEMENT

Iliamna residents want to be kept informed about issues pertaining to local governance and to take action only as it becomes necessary.

## ACTION PLAN

To achieve the Governance goal, the residents of Iliamna have identified the following actions:

- ★ Issues should only be dealt with as they become issues of importance to the community.
- ★ Efforts should be made not to upset the working relationship that exists between the various groups of people within the community.
- ★ Residents want to be kept informed of the issues concerning Iliamna's governance.
- ★ Efforts should be made to keep the communications with Newhalen open.
- ★ Residents should be kept informed of borough actions.
- ★ Iliamna and Newhalen residents need to work towards a healing between the two communities.
- ★ Iliamna needs to develop a sense of community focus.
- ★ Seek ways to keep the State Trooper in Iliamna.

# COMMUNITY

## GOAL STATEMENT

The residents of Iliamna want to maintain the friendliness and neighborliness of the community, encourage active participation by all members of the community and to improve relations and communications between residents and seasonal business operators.

## ACTION PLAN

To achieve the Community goal, the residents of Iliamna have identified the following actions:

- ★ Set up a series of meetings with residents and lodge operators and staff.
- ★ Conduct winter community functions such as a carnival, pot lucks, and recreational activities for all ages.
- ★ Provide information on community services to campers and sports fishermen and inform them how to respect community concerns.

# FACILITIES

## GOAL STATEMENT

Iliamna residents want to have facilities that improve the quality of life, and are financially supportable, cost-effective and based on existing and foreseeable future needs.

## ACTION PLAN

To achieve the Facilities goal, the residents of Iliamna have identified the following actions:

- ★ Identify and select 14(c)(3) sites to settle this issue.
- ★ Identify operational and maintenance costs of existing and proposed facilities.
- ★ Develop a landfill operation and maintenance plan.
- ★ Identify a sewage lagoon site.
- ★ Identify sites for parks and recreational areas.
- ★ Identify sites for future public buildings and an elders home.
- ★ Respect the land holdings of INL and APC.

## How Can We Accomplish These Goals?

Now that a set of goals have been identified and activities to accomplish the goals described, how can they be achieved?

Iliamna can obtain a better future if the community works together. All residents should become responsible for achieving the community's goals. A handful of involved residents cannot do it alone. The village council may be able to provide leadership but all members of the community **MUST** become involved in preparing for the future of Iliamna.