



# Comprehensive Energy Audit For

## Manokotak Clinic



---

Prepared For  
**City of Manokotak**

**May 15, 2018**

**Prepared By: Kevin Ulrich, CEM**

**Alaska Native Tribal Health Consortium  
4500 Diplomacy Drive  
Anchorage, AK 99508**

## Table of Contents

PREFACE .....	2
ACKNOWLEDGMENTS.....	2
OVERVIEW.....	3
ENERGY BASELINE .....	3
PROPOSED ENERGY EFFICIENCY MEASURES (EEM).....	3
FACILITY DESCRIPTION .....	5
PROJECT FINANCING.....	8
MEASUREMENT AND VERIFICATION .....	8
Appendix A –Energy Billing Data.....	9
Appendix B – Energy Audit Report – Project Summary.....	10
Appendix C – Actual Fuel Use versus Modeled Fuel Use.....	11
Appendix D - EUI Calculation Details .....	12
Appendix E – Materials List and Labor Estimation.....	13
Appendix F – Materials Specifications .....	14

## PREFACE

The purpose of this report is to provide guidance in reducing facility operating costs and enhance the sustainability of this community. The report assesses the current energy usage of the facility, provide options for reducing the amount of energy used, and evaluate the cost vs. benefit of each option.

Discussions of site specific concerns, financing options, general facility information, and an Energy Efficiency Action Plan are also included in this report.

## ACKNOWLEDGMENTS

The Rural Energy Initiative gratefully acknowledges the assistance of the staff and faculty at the Manokotak Clinic.

# OVERVIEW

This report was prepared for the Bristol Bay Area Health Corporation. The scope of the audit focused on the Manokotak Clinic and includes an analysis of building occupancy schedules, building shell, heating systems, heating and ventilations systems, domestic hot water, lighting, and other electrical loads. The Manokotak Clinic is a wood-framed building built on an elevated pile foundation and is approximately 2,557 square feet in area. The building provides medical services to the residents of the community.

Annual Energy Costs by Fuel Type

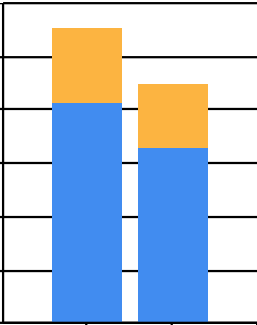

## ENERGY BASELINE

Based on unsubsidized electricity and fuel oil prices in effect at the time of the audit, the total predicted energy costs are \$27,780 per year. This includes \$20,776 for unsubsidized electricity and \$7,004 for #1 fuel oil.

The State of Alaska Power Cost Equalization (PCE) program provides a subsidy to rural communities across the state to lower electricity costs and make energy affordable in rural Alaska. In Manokotak the cost of electricity without PCE is \$0.57/kWh and the cost of electricity with PCE is \$0.27/kWh. With the PCE subsidy, the electric utility cost to the Manokotak Clinic is \$9,841 and the cost to the State of Alaska is \$10,935.

Table 1 lists the predicted annual energy usage before and after the proposed retrofits for the Manokotak Clinic.

Table 1: Predicted Annual Energy Use for the Manokotak Clinic

Predicted Annual Fuel Use				
Fuel Use	Existing Building	With Proposed Retrofits	Total Energy Savings	Total Cost Savings (Subsidized)
Electricity	36,449 kWh	29,146 kWh	7,303 kWh	\$1,972
#1 Oil	1,556 gallons	1,309 gallons	247 gallons	\$988

## PROPOSED ENERGY EFFICIENCY MEASURES (EEM)

Table 2 below summarizes the energy efficiency measures analyzed for the Manokotak Clinic. Listed are the estimates of the annual savings, installed costs, and two different financial measures of investment return. All costs assume that local labor will be used with no additional cost associated for travel or administrative tasks.

**Table 2: Priority List – Energy Efficiency Measures**

Priority	Feature	Improvement Description	Annual Energy Savings	Installed Cost	Savings to Investment Ratio, SIR <sup>1</sup>	Simple Payback (Years) <sup>2</sup>	CO <sub>2</sub> Savings
High	Setback Thermostat: Arctic Entry	Implement a heating temperature unoccupied setback to 60.0 deg F.	\$816	\$200	50.24	0.2	3,854.6
High	Lighting: E1 Surface Utility (wall pack)	Replace with new direct-wire, LED equivalent light bulbs.	\$246	\$72	50.16	0.3	1,131.8
High	Lighting: G1 Wall Mounted Area Flood	Replace with new direct-wire, LED equivalent light bulbs.	\$634	\$208	44.54	0.3	3,003.9
High	Setback Thermostat: Office	Implement a heating temperature unoccupied setback to 60.0 deg F.	\$551	\$200	33.90	0.4	2,600.9
High	Setback Thermostat: TDY/Kitchen	Implement a heating temperature unoccupied setback to 60.0 deg F.	\$464	\$200	28.54	0.4	2,189.4
High	Setback Thermostat: Laundry/Storage	Implement a heating temperature unoccupied setback to 60.0 deg F.	\$404	\$200	24.91	0.5	1,910.5
High	Setback Thermostat: Waiting Room	Implement a heating temperature unoccupied setback to 60.0 deg F.	\$387	\$200	23.82	0.5	1,827.5
High	Setback Thermostat: ADA Restroom	Implement a heating temperature unoccupied setback to 60.0 deg F.	\$229	\$200	14.08	0.9	1,080.3
High	Setback Thermostat: Telecom	Implement a heating temperature unoccupied setback to 60.0 deg F.	\$228	\$200	14.05	0.9	1,077.9
High	Setback Thermostat: Mechanical Room	Implement a heating temperature unoccupied setback to 60.0 deg F.	\$197	\$200	12.12	1.0	930.0
High	Setback Thermostat: ADA/Bath	Implement a heating temperature unoccupied setback to 60.0 deg F.	\$197	\$200	12.10	1.0	928.1
High	Setback Thermostat: Side Arctic Entry	Implement a heating temperature unoccupied setback to 60.0 deg F.	\$111	\$200	6.85	1.8	525.3
High	Setback Thermostat: Pharmacy/Storage	Implement a heating temperature unoccupied setback to 60.0 deg F.	\$88	\$200	5.41	2.3	415.0
High	Setback Thermostat: Lab	Implement a heating temperature unoccupied setback to 60.0 deg F.	\$52	\$200	3.20	3.9	245.3
Medium	Lighting: B3 EM 2x4 Troffer, recessed, lensed with emergency ballast	Replace with new direct-wire, LED equivalent light bulbs.	\$198	\$1,592	1.95	8.0	868.8
Medium	Lighting: A3 EM 2x4 Recessed sealed troffer	Replace with new direct-wire, LED equivalent light bulbs.	\$28	\$228	1.94	8.1	124.1
Medium	Lighting: A2 EM 2x4 Statictroffer, spec premium	Replace with new direct-wire, LED equivalent light bulbs.	\$73	\$607	1.89	8.3	327.1
Medium	Lighting: C2 1x4 Wraparound	Replace with new direct-wire, LED equivalent light bulbs.	\$115	\$1,061	1.70	9.2	498.9

Priority	Feature	Improvement Description	Annual Energy Savings	Installed Cost	Savings to Investment Ratio, SIR <sup>1</sup>	Simple Payback (Years) <sup>2</sup>	CO <sub>2</sub> Savings
Medium	Lighting: A2 2x4 Static troffer, spec premium	Replace with new direct-wire, LED equivalent light bulbs.	\$16	\$152	1.66	9.4	71.3
Medium	Air Tightening	Weatherize around the doors.	\$71	\$470	1.31	6.6	335.0
Medium	Lighting: C2 EM 1x4 Wraparound	Replace with new direct-wire, LED equivalent light bulbs.	\$21	\$303	1.04	14.4	86.9
Low	Lighting: B3 2x4 Troffer, recessed, lensed	Replace with new direct-wire, LED equivalent light bulbs.	\$71	\$1,137	0.93	16.0	286.8
Low	Lighting: A3 2x4 Recessed sealer troffer	Replace with new direct-wire, LED equivalent light bulbs.	\$71	\$1,137	0.93	16.1	285.4
Low	Lighting: C3 Turret Industrial Lithonia AF20 2 32 120 GEB1015	Replace with new direct-wire, LED equivalent light bulbs.	\$28	\$455	0.91	16.3	112.2
Low	HVAC And DHW	Clean and tune boiler. Set back temperature to 120 deg. F.	\$50	\$1,865	0.25	37.3	234.5
<b>TOTAL</b>			<b>\$5,346</b>	<b>\$11,687</b>	<b>5.94</b>	<b>2.2</b>	<b>24,951.3</b>

## FACILITY DESCRIPTION

### Building Occupancy Schedules

The building is occupied from 9:00 AM – 3:00 PM for five days per week when the clinic is open for the community.

### Building Shell

The building is a wood-framed lumber construction that is built on an elevated foundation with an insulated crawlspace.

There are 10 total windows in the building. Each window has double-pane glass with vinyl framing and is approximately 36" x 44" in dimension. Four of the ten windows are south facing.

There are three total entrances to the building. All of the entrances are single insulated metal doors with quarter-lite windows.

### Heating Systems

The heating systems used in the building are:

#### **B-1 Boiler**

Nameplate Information: Weil McLain Gold Oil P-WGO-4  
Fuel Type: #1 Oil

Input Rating:	145,000 BTU/hr
Steady State Efficiency:	85 %
Idle Loss:	1.5 %
Heat Distribution Type:	Glycol
Boiler Operation:	All Year
Notes:	#1 fuel oil

### **WH-1 Water Heater**

Nameplate Information:	Toyotomi OM-148
Fuel Type:	#1 Oil
Input Rating:	148,000 BTU/hr
Steady State Efficiency:	87 %
Idle Loss:	1.5 %
Heat Distribution Type:	Water
Boiler Operation:	All Year
Notes:	#1 fuel oil, 148 MBH output. OPT-91UL Laser Clean Direct Vent Hating System Oil Lifter Pump (16W)

### **Space Heater**

Nameplate Information:	Patton 1500 W
Fuel Type:	Electricity
Input Rating:	0 BTU/hr
Steady State Efficiency:	100 %
Idle Loss:	0 %
Heat Distribution Type:	Air
Notes:	Used as needed

### **Space Heating Distribution Systems**

Space heating is achieved through a baseboard distribution system that transports heated glycol throughout the building to disperse the heat through baseboard units. There are also two cabinet heaters in the hydronic loop as well. One of the cabinet unit heaters is rated for 10,700 BTU/hr and one of the units is rated for 4,800 BTU/hr.

### **Domestic Hot Water System**

There are sinks present in every patient room as well as two kitchen areas with sinks that are used by clinic staff. There are also two restrooms in the facility and a clothes washer to clean faculty and patient clothing.

## Description of Building Ventilation System

**Table 3: Ventilation Information in the Manokotak Clinic**

Label	Location	Rating (Watts)	CFM	Annual Energy Consumption (kWh)
HRV-1	Mechanical Room	610	800	1,563
EF-1	Telecom	80	150	3,194
EF-2	Morgue	45	55	324
EF-3	Crawlspace	45	55	369

## Lighting

**Table 4: Lighting Information in the Manokotak Clinic**

Location	Bulb Type	Fixtures	Bulbs per Fixture	Annual Usage (kWh)
Interior	Fluorescent T8 4ft.	17	2	1,555
Interior	Fluorescent T8 4ft.	18	3	2,513
Exterior	Fluorescent GU24	7	1	1,109
Exterior	High Pressure Sodium 35 Watt	2	1	721
Exterior	High Pressure Sodium 150 Watt	1	1	1,479

## Other Electrical Loads

There is a variety of office equipment and phones that are used during the day that use a small amount of energy throughout the year.

## Major Equipment

**Table 5: Major Electrical Equipment in the Manokotak Clinic**

Equipment	Rating (Watts)	Annual Usage (kWh)
Glycol Make-Up Tank	29	1
Sump Pump	185	290
X-Ray Viewing Screen	14	1
Heat Tape	2,400	36
Clothes Washer	1,800	470
TV/VCR Unit	200	5
Medical Cart	1,200	319
Medical Diagnostic Equipment (4)	~ 18 each	19
Computers (6)	~ 252 each	1,183
Desk Phones (10)	~ 4 each	331
Centrifuge	184	5

Coffee Pot (2)	~900 each	235
Small Printers (2)	~ 27 each	2
Large Printer	250	11
X-Ray Printer	575	3
Dental Vacuum	1,840	48
Dental Compressor	1,119	29
Fire/Security Alarm	5	47
Refrigerator	43	380

## PROJECT FINANCING

The total estimated cost of the recommended EEM’s \$11,687. The payback for the implemented EEM’s is approximately 2.2 years. ANTHC is willing to assist the community with acquiring funds to complete the scope of work recommended in this energy audit.

There are several options for financing energy efficiency projects within the State of Alaska. These include the use of grants, loans, and other funding opportunities. Below is some information on potential funding opportunities.

**Energy Efficiency Revolving Loan Program** – This is a loan administered by the Alaska Housing Finance Corporation (AHFC) for use by any applicant who is also the owner of the building where the work will take place. It provides a loan for permanent energy-efficiency projects with a completion window of one year.

**Sustainable Energy Transmission and Supply Program** – This is a loan administered by the Alaska Energy Authority (AEA) for a government, business, or other organized body of people. It provides a loan for energy-efficiency or power transmission or distribution projects.

**USDA-RD Communities Facilities Direct Loan & Grant Program** - This is a loan or grant provided by the US Department of Agriculture – Rural Development (USDA-RD) for any essential community facility in a rural area. It provides a loan or grant to develop essential community facilities with upgrades or equipment for improvement.

## MEASUREMENT AND VERIFICATION

The results of these recommended measures can be measured through the collection of energy use data through the monthly bills provided by the local electric utility and the local fuel oil supplier. Collecting data and performing a historical comparison is the simplest method of validating the energy and cost savings seen by the measures. Additionally, active remote monitoring systems are available that can collect and store data regarding energy and fuel usage. These systems allow the user to track the usage in real time and can be shared more easily with partners across the state.

# APPENDICES

## Appendix A –Energy Billing Data

The table below shows the fuel and electricity data used during the energy modeling process to confirm the accuracy of the energy distribution. The fuel use distribution was estimated based on the times of each fuel delivery, which were not in a precisely monthly basis.

<b>Month</b>	<b>Fuel Oil Use (gallons)</b>	<b>Electricity Use (kWh)</b>
January	200	Not Received
February	200	Not Received
March	160	Not Received
April	135	Not Received
May	80	Not Received
June	50	Not Received
July	50	Not Received
August	50	Not Received
September	80	Not Received
October	135	Not Received
November	160	Not Received
December	200	Not Received

# Appendix B – Energy Audit Report – Project Summary

ENERGY AUDIT REPORT – PROJECT SUMMARY	
General Project Information	
PROJECT INFORMATION	AUDITOR INFORMATION
<b>Building:</b> Manokotak Clinic	<b>Auditor Company:</b> Alaska Native Tribal Health Consortium
<b>Address:</b> Manokotak	<b>Auditor Name:</b> Kevin Ulrich
<b>City:</b> Manokotak	<b>Auditor Address:</b> 4500 Diplomacy Drive
<b>Client Name:</b> Stella Pauk	Anchorage, AK 99508
<b>Client Address:</b> P.O. Box 170 Manokotak, AK 99628	<b>Auditor Phone:</b> (907) 729-3237
<b>Client Phone:</b> (907) 289-1027	<b>Auditor FAX:</b> (907) 729-4047
<b>Client FAX:</b> (907) 289-1082	<b>Auditor Comment:</b> Assistant auditor: Kelli Whelan, MS Env Eng (907) 729-3723, kmwhelan@anthc.org
Design Data	
<b>Building Area:</b> 2,557 square feet	<b>Design Space Heating Load:</b> Design Loss at Space: 82,431 Btu/hour with Distribution Losses: 82,431 Btu/hour Plant Input Rating assuming 82.0% Plant Efficiency and 25% Safety Margin: 125,657 Btu/hour Note: Additional Capacity should be added for DHW and other plant loads, if served.
<b>Typical Occupancy:</b> 24 people	<b>Design Indoor Temperature:</b> 72 deg F (building average)
<b>Actual City:</b> Manokotak	<b>Design Outdoor Temperature:</b> -17.2 deg F
<b>Weather/Fuel City:</b> Manokotak	<b>Heating Degree Days:</b> 10,828 deg F-days
Utility Information	
<b>Electric Utility:</b> Manokotak Power Company	<b>Average Annual Cost/kWh:</b> \$0.57/kWh

Annual Energy Cost Estimate								
Description	Space Heating	Water Heating	Ventilation Fans	Clothes Drying	Lighting	Refrigeration	Other Electrical	Total Cost
<b>Existing Building</b>	\$18,742	\$1,008	\$983	\$895	\$4,204	\$217	\$1,730	<b>\$27,780</b>
<b>With Proposed Retrofits</b>	\$15,271	\$1,008	\$983	\$895	\$2,398	\$217	\$1,730	<b>\$22,502</b>
<b>Savings</b>	\$3,471	\$0	\$0	\$0	\$1,806	\$0	\$0	<b>\$5,278</b>

Building Benchmarks			
Description	EUI (kBtu/Sq.Ft.)	EUI/HDD (Btu/Sq.Ft./HDD)	ECI (\$/Sq.Ft.)
<b>Existing Building</b>	129.0	11.91	\$10.86
<b>With Proposed Retrofits</b>	106.4	9.83	\$8.80

EUI: Energy Use Intensity - The annual site energy consumption divided by the structure's conditioned area.  
 EUI/HDD: Energy Use Intensity per Heating Degree Day.  
 ECI: Energy Cost Index - The total annual cost of energy divided by the square footage of the conditioned space in the building.

# Appendix C – Actual Fuel Use versus Modeled Fuel Use

The graphs below show the modeled energy usage results of the energy audit process compared to the actual energy usage report data. The model was completed using AkWarm modeling software. The orange bars show actual fuel use, and the blue bars are AkWarm’s prediction of fuel use.

### Annual Energy Use

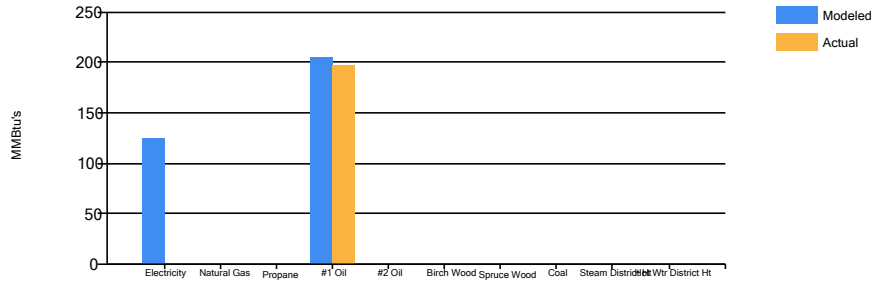

### Electricity Use

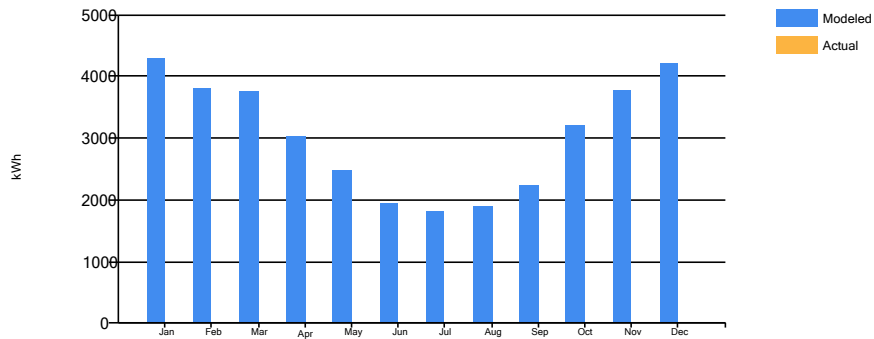

### #1 Fuel Oil Use

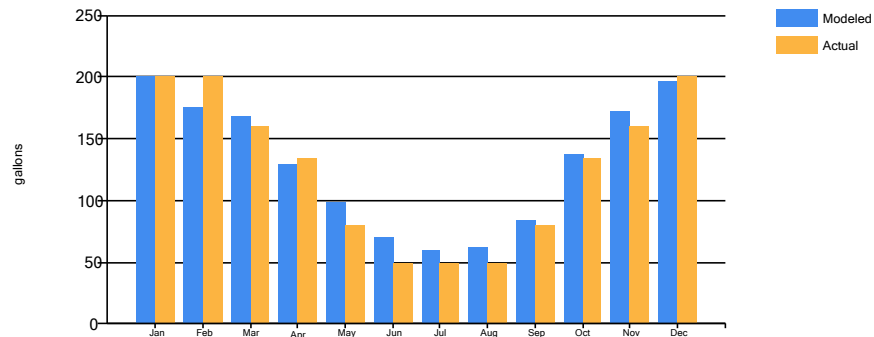

## Appendix D - EUI Calculation Details

The Manokotak Power Company owns and operates the utility that provides electricity to the residents of the community as well as to all the commercial and public facilities.

The average cost for each type of fuel used in this building is shown below in Table 6. This figure includes all surcharges, subsidies, and utility customer charges:

**Table 6: Energy Cost Rates for each Fuel Type.**

Average Energy Cost	
Description	Average Energy Cost
Electricity	\$ 0.57/kWh
#1 Oil	\$ 4.00/gallons

Table 7 shows the calculated results for the building Energy Use Index (EUI), which determines the total energy usage for a type of building for comparison with other buildings of the same type. This allows the user to determine the relative energy use of a building in relation to others of the same type or use.

**Table 7: EUI Building Calculations for the Manokotak Clinic**

Energy Type	Building Fuel Use per Year	Site Energy Use per Year, kBTU	Source/Site Ratio	Source Energy Use per Year, kBTU
Electricity	36,449 kWh	124,399	3.340	415,492
#1 Oil	1,556 gallons	205,446	1.010	207,500
<b>Total</b>		<b>329,844</b>		<b>622,992</b>
BUILDING AREA 2,557 Square Feet				
BUILDING SITE EUI 129 kBTU/Ft <sup>2</sup> /Yr				
<b>BUILDING SOURCE EUI 244 kBTU/Ft<sup>2</sup>/Yr</b>				
* Site - Source Ratio data is provided by the Energy Star Performance Rating Methodology for Incorporating Source Energy Use document issued March 2011.				

Table 7 shows information on common energy use benchmarks used to characterize the efficiency of a building.

**Table 7: Building Benchmarks for the Manokotak Clinic**

Building Benchmarks			
Description	EUI (kBtu/Sq.Ft.)	EUI/HDD (Btu/Sq.Ft./HDD)	ECI (\$/Sq.Ft.)
Existing Building	129.0	11.91	\$10.86
With Proposed Retrofits	106.4	9.83	\$8.80
EUI: Energy Use Intensity - The annual site energy consumption divided by the structure's conditioned area. EUI/HDD: Energy Use Intensity per Heating Degree Day. ECI: Energy Cost Index - The total annual cost of energy divided by the square footage of the conditioned space in the building.			

## Appendix E – Materials List and Labor Estimation

**Table 8 & 9: Materials List and Cost Estimation for Manokotak EEM’s**

Energy Retrofit	Required Materials	Quantity	Cost per Item	Total Materials Cost
Setback Thermostats	Programmable Thermostats	12	150	1,500
Clean and Tune Boilers	Air Filter, Fuel Meter	1	400	400
LED Lighting	T8 LED light bulb equivalents	92	15	1,380
LED Lighting	High Pressure Sodium 35 Watt equivalent	1	25	25
LED Lighting	GU24 LED 11 Watt equivalent	3	25	75
Air Tightening	Caulking	3	25	75

Category	Cost (\$)
Labor	4,995
Travel	1,650
Materials	3,455
Freight	518
Indirect	1,062
<b>Total</b>	<b>\$11,680</b>

This energy audit cost information assumes that all work will be completed by an employee from outside of the community. If local labor is used for the retrofits, the travel and indirect costs may be removed from the total estimated cost. The boiler cleaning and setback thermostat retrofits will likely require outside labor.

# Appendix F – Materials Specifications

# Robertshaw®

# 9701i2

DELUXE  
PROGRAMMABLE  
THERMOSTAT



GAS



ELECTRIC



OIL



HEAT PUMP

Menu Driven Display 1 Heat / 1 Cool

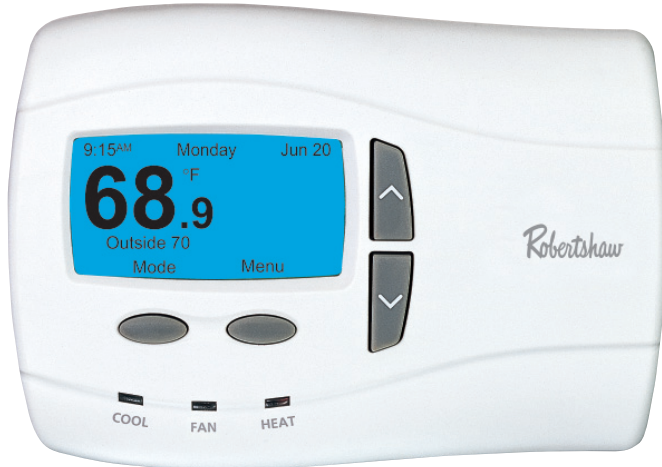

## Programming Made Even Easier

**Do you want to spend less time installing and setting up thermostats?**

The new 9701i2 makes installation even easier with our new Setup Wizard. The Setup Wizard allows you to spend 50% less time setting up the thermostat over competitive models. Plus everything is in plain language so there are no complicated codes or button combinations to memorize.

We've also made programming even easier for your customers. Menus are easier to navigate. We've even added additional convenience features such as Automated Time adjustment for Daylight Saving Time, along with new indoor air quality reminders.

The new 9701i2 is so user friendly, it sets a higher standard in efficiency and simplicity for programmable thermostats. It is truly programming made even easier.

Robertshaw - *Simply the Right Choice™*

## Features and Benefits

Would You Like To Run the Setup Wizard?

No Yes

### Set-up Wizard

Helps speed through the installation process with step-by-step setup and programming instructions.

Select Language

English  
Español  
Français

Back Next

### Trilingual Display Option

Set to your customers' language of choice – English, Spanish or French

Mon To Sun Program

		HEAT	COOL
Wake	6:00 AM	70	78
Morn	8:00 AM	62	65
Eve	5:00 PM	70	78
Night	10:00 PM	62	62
Exit		Select	

### Convenient Displays

View a full day of programming at once for quick review or easy adjustment.

Tech Support

Model 9701i vX.X  
ABC HEAT  
555-1234  
ROBERTSHAW  
(800) 445-8299

### Contractor ID Feature

Set it yourself or custom order with your information pre loaded. Your name and phone number remind your customers when service is needed.

### Daylight Saving Time Adjustment

Automatically adjusts to correct time regardless of seasonal changes.

### Adjustable Backlighting

Choose to have backlighting on at all times or only when programming. You can also adjust the brightness and contrast for improved readability.

### Time of Day Zoning

When coupled with a remote sensor (part #9020i), you can control the temperature in remote locations given different scheduled events.

### Three Levels of Security

Secure protection against unwanted changes to the programming menus, temperature or set-up functions with your own 4-digit PIN.

### Auto Changeover

Automatically adjusts between heating and cooling cycles to maintain optimal comfort.

### Worry-Free Memory Storage

Even during power outages, the thermostat maintains set point and programmed parameters.

### Adjustable Temperature Offset

Change the displayed temperature from the actual sensed temperature.

### Adjustable Temperature Differential

Maintains optimal customer comfort.

### Intermittent Fan

Maintains optimal air filtration and circulation with minimal energy use.

An ISO 9001 – 2008 Certified Company

California Title 24 Compliant



5 Year  
Limited  
Warranty

24V AC POWERED

# Robertshaw®

# 9701i2 DELUXE PROGRAMMABLE THERMOSTAT

## Terminal Designations

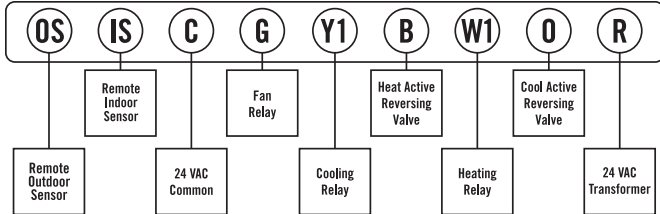

## Technical Specifications

<b>Electrical Rating</b>	24 Volt AC (18-30 VAC) 1 amp maximum load per terminal (relay outputs) 3 amp total maximum load (all terminals combined)
<b>Temperature Control Range</b>	45°- 90°F (7°- 32°C)
<b>Accuracy</b>	+/-1.0°F (+/-0.5°C)
<b>Power Source</b>	24 VAC
<b>Auto Changeover Deadband</b>	Selectable 2° to 8°F
<b>Temporary Temperature Override</b>	3 hour maximum or next setpoint
<b>Remote Sensor Capable</b>	1 indoor and 1 outdoor sensor
<b>System Configurations</b>	Single-stage gas, oil or electric heating/cooling systems and single stage heat pump
<b>Terminations</b>	R, W1, Y1, B, O, G, C, IS, OS

## Shipping Specifications

Indiv. Ctn. Dim.: 6.625" x 4.25" x 1.625"	<b>Item 9020i and 9025i Remote Sensors</b>
Master Ctn. Qty.: 6	Indiv. Ctn. Dim.: 2.625" x 1.5625" x 4.4375"
Master Ctn. Dim.: 9.25" x 5.625 x 7.5"	Master Ctn. Qty.: 6
Master Ctn. Cu. Ft.: .23	Master Ctn. Dim.: 5.625" x 5.125" x 5.125"
Master Ctn. Wt.: 3.5 lbs.	Master Ctn. Cu. Ft.: .09
Max. Pallet Qty.: 1260	Master Ctn. Wt.: .78 lbs.
Max. Pallet Wt.: 785 lbs.	

## Replacement Chart

9701i2	
Braeburn®	5000
Honeywell	TH8110U1003
White-Rodgers	1F95-1271, 1F90-51, 1F90-71, 1F90-371, 1F97-51, 1F97-71, 1F97-371
Carrier	TC-PAC, TC-PHP, P274-1100, P374-1100, P474-1100
Lux	PSPA711

Verify specific application requirements before substitution.

## Patent Information

This product is covered by one or more of the following U.S. patents. Foreign patent rights may be pending. 4967382, 5803357, 6502758, 7000849, D301207, D462940

**invenSYS**  
Controls

191 E. North Avenue  
Carol Stream Illinois 60188 USA  
Customer Service Telephone 1.800.304.6563  
Customer Service Facsimile 1.800.426.0804  
HVACCustomerService@InvenSysControls.com

For Technical Service  
Telephone 1.800.445.8299  
Facsimile 1.630.260.7294  
TechnicalService@InvenSysContrtols.com

InvenSys™, Robertshaw® and Simply the Right Choice™ are trademarks of InvenSys plc., its subsidiaries and/or affiliated companies. All other brands mentioned in this report may be the trademarks of their respective owners.

**www.RobertshawTstats.com**  
**www.InvenSysControls.com**  
©2009 InvenSys Controls 10/09 - 150-1978B



**Optional Sensors:**  
9020i: REMOTE INDOOR  
9025i: REMOTE OUTDOOR

## Feature Comparison

	InvenSys i2-Series	Honeywell Vision Pro	Carrier Infinity	White-Rodgers 1F97-371
Menu Driven (Ease of Programming)	X			
Installation Wizard	X			
Displays Complete Program	X			
Adjustable Backlighting	X			
Cooling System Monitor	X			
Heating System Monitor	X			
Multi-Language	X			
1/2 Degree Resolution	X			
Time of Day Zoning	X			
5/2 Program	X			X
24 Hour Programming	X			X
7-Day Programming	X	X	X	
Large Display	X	X	X	
Adjustable Timed Override/Hold	X	X		
Automatic Daylight Saving Time Adjustment	X	X		
Adjustable Temperature Limits	X	X		
High/Low Balance Points	X	X		
LED Status Indicators	X	X		
Adjustable Differential	X	X		
Adjustable Compressor Short Cycle Protection	X	X		
Adjustable Residual Cooling	X	X		
Fossil Fuel Kit required on HP units	No	No	Yes	Yes
Battery Free Memory Retention	X		X	
Manual Override	X	X	X	X
Resume	X	X	X	X
Auto Changeover	X	X	X	X
Gas/Electric	X	X	X	X
Single Stage Heat Pump Compatible	X	X	X	X
Line Powered	X	X	X	X
Programmable Fan	X	X	X	X
Intermittent Fan	X		X	
°F and °C	X	X	X	X
12 or 24 Hour	X	X		X
Air Filter Monitor	X	X	X	X
Humidifier Pad Monitor	X	X	X	
UV Light Monitor	X	X	X	
Vacation Setting	X	X	X	X
O & B Terminals	X	X	Partial	X
Events per day	2, 4, 6	4	4	2, 4
Remote Outdoor Sensor	X	Combo	X	X
Remote Indoor Sensor	X		X	X
Energy Efficient Recovery	X	X	X	X
Pre-set Program	X	X	X	X
Hidden Service Level	X	X	X	
Security Key Pad	X			X
Temperature Recalibration	X	X	X	
Customizable Contractor ID	X			Factory Only

**NOTE:** Always keep the thermostat's vents clean and unobstructed.

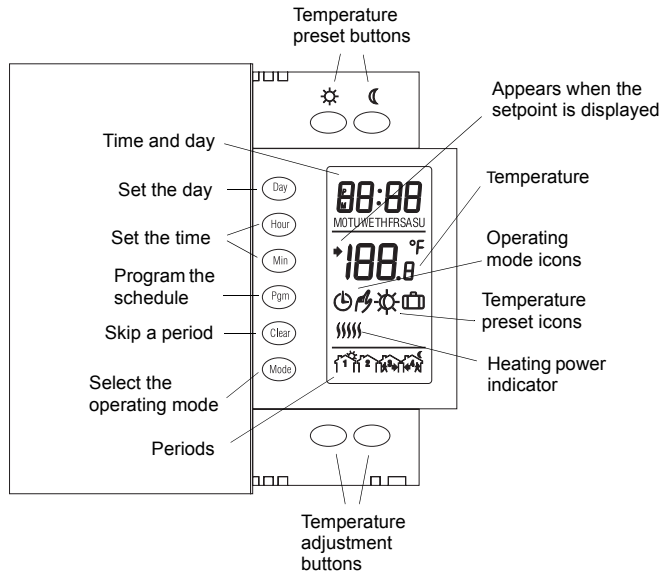

## 1 Description

This programmable thermostat can be used to control an electric heating system such as an electric baseboard heater, a radiant ceiling, a radiant floor, a convector, etc.

The thermostat cannot be used under the following conditions:

- The resistive load is greater than 16.7 A
- The resistive load is less than 2 A
- The system is driven by a contactor or relay (inductive load)
- The system is a central heating system

### SUPPLIED PARTS:

- One (1) thermostat
- Two (2) 6-32 screws
- Two (2) solderless connectors

## 2 Installation

**TURN OFF POWER TO THE HEATING SYSTEM AT THE MAIN POWER PANEL TO AVOID ELECTRICAL SHOCK.**

**THE INSTALLATION MUST BE PERFORMED BY AN ELECTRICIAN.**

- ▶ All cables and connections must conform to the local electrical code.
- ▶ Special CO/ALR solderless connectors must be used when connecting with aluminum conductors.
- ▶ Install the thermostat onto an electrical box.
- ▶ Install the thermostat about 5 feet high, on an inside wall facing the heater.
- ▶ Avoid locations where there are air drafts (such as the top of a staircase or an air outlet), dead air spots (such as behind a door), or direct sunlight.
- ▶ Do not install the thermostat on a wall that conceals chimney or stove pipes.
- ▶ The thermostat wires are not polarized; either wire can be connected to the load or to the power supply.

1

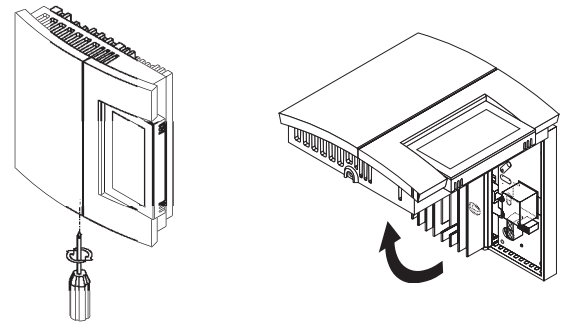

2 Connect the thermostat wires to the line wires and to the load wires using solderless connectors for copper wires.

### 2-wire installation

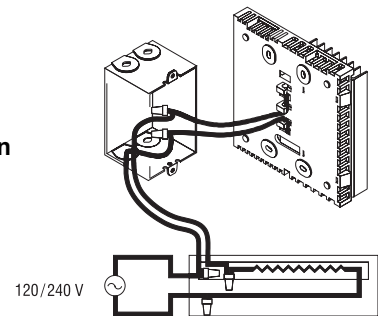

### 4-wire installation

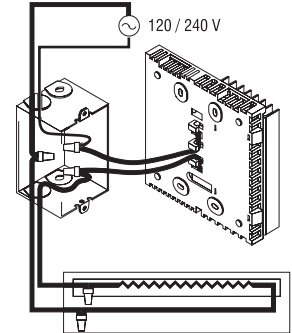

3 Push any excess wire back into the electrical box.

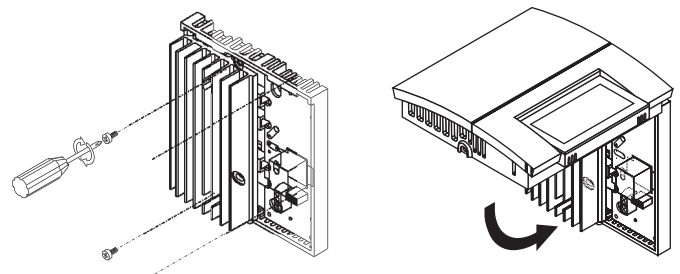

**NOTE:** If necessary, before re-installing the front component, configure the thermostat (see section 3).

4 Return power to heating system.

### 3 Configuration

The configuration switches are on the back of the thermostat. The factory settings are indicated by the gray cells in the following table.

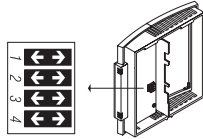

SW1	Early Start <sup>a</sup>	Off	On
SW2	Temperature / time format <sup>b</sup>	°C / 24-hour	°F / 12-hour
SW3	Cycle length <sup>c</sup>	15 seconds	15 minutes
SW4	Not used	-	-

- Early Start can be used in Automatic mode only. When this function is enabled, the thermostat calculates the optimal time to start heating in order to obtain the desired temperature by the set time. The thermostat re-assesses the start time daily based on the previous day's performance.
- If you change the temperature display format, the preset temperatures (☼, ☾ and ☰) will return to their default settings.
- 15-second cycles should be selected in most cases as it provides better temperature control. 15-minute cycles must be selected if you have a fan-equipped heater or if 15-second cycles causes light flickering (especially in rural regions).

### 4 Power-up

Upon power-up, the thermostat is in manual mode (☼) and displays the actual (ambient) temperature.

- Press the **Hour** and **Min** buttons to set the thermostat's clock.
- Press the **Day** button to set the day.

### 5 Temperature Setting

#### Setpoint

The thermostat normally displays the actual temperature. To view the setpoint, press the ▲ or ▼ button briefly. The setpoint will appear for the next 5 seconds.

To change the setpoint, press the ▲ or ▼ button until the desired temperature is displayed. To scroll faster, hold the button.

#### Using a preset temperature

The thermostat has 3 preset temperatures:

- Comfort temperature ☼
- Economy temperature ☾
- Vacation temperature ☰

Icon	Intended use	Factory setting
☼	Comfort (when at home)	21°C (70°F)
☾	Economy (when asleep or away from home)	16.5°C (62°F)
☰	Vacation (during prolonged absence)	10°C (50°F)

- To use the Comfort or Economy temperature, press the ☼ or ☾ button respectively. The corresponding icon will be displayed.
- To use the Vacation temperature, press both ☼ and ☾ buttons simultaneously. The ☰ icon will be displayed.

#### Storing a preset temperature

To store the Comfort or Economy temperature:

Set the desired temperature using the ▲ or ▼ button. Press and hold the appropriate button (☼ or ☾) for approximately 3 seconds until the corresponding icon is displayed. Press the **Mode** button.

To store the Vacation temperature:

Set the desired temperature using the ▲ or ▼ button. Press and hold both ☼ and ☾ buttons simultaneously for approximately 3 seconds until the ☰ icon is displayed. Press the **Mode** button.

### 6 Operating Modes

⌚ **Automatic** - The temperature is set according to the programmed schedule. To place the thermostat in this mode, press **Mode** until ⌚ is displayed. The icons of the current period and preset temperature are also displayed.

**Temporary Bypass:** If you modify the setpoint (by pressing the ▲, ▼, ☼ or ☾ button) when the thermostat is in automatic mode, the new setpoint will be used until the end of the current period. When the next period starts, the temperature set for that period becomes the new setpoint.

☼ **Manual** - The programmed schedule is not used. The temperature must be set manually. To place the thermostat in this mode:

- Press **Mode** until ☼ is displayed.
- Set the temperature using the ▲, ▼, ☼ or ☾ button.

### 7 Schedule

The schedule consists of 4 periods per day which represents a typical weekday. You can program the thermostat to skip the periods that do not apply to your situation. For example, you can skip periods 2 and 3 for the weekend.

Period	Description	Associated temperature preset
☼	Wake	☼
☾	Leave	☾
☼	Return	☼
☾	Sleep	☾

The Comfort (☼) temperature is used in periods 1 and 3 and the Economy (☾) temperature is used in periods 2 and 4. For example, when the period changes from 1 to 2, the setpoint automatically changes from Comfort setting (☼) to Economy setting (☾).

You can have a different program for each day of the week; i.e., each period can start at different time for each day of the week. The thermostat has been programmed with the following schedule.

Period	Setting	MO	TU	WE	TH	FR	SA	SU
☼	☼	6:00 AM	6:00 AM	6:00 AM	6:00 AM	6:00 AM	6:00 AM	6:00 AM
☾	☾	8:00 AM	8:00 AM	8:00 AM	8:00 AM	8:00 AM	--:--	--:--
☼	☼	6:00 PM	6:00 PM	6:00 PM	6:00 PM	6:00 PM	--:--	--:--
☾	☾	10:00 PM	10:00 PM	10:00 PM	10:00 PM	10:00 PM	10:00 PM	10:00 PM

To modify the schedule:

- Press **Pgm** to access the programming mode. Period 1 is selected.
- Press **Day** to select the day to program (hold for 3 seconds to select the entire week).
- Press **Hour** and **Min** to set the start time of the selected period, or press **Clear** if you want to skip the period (--:-- is displayed).
- Press **Pgm** to select another period, or press **Day** to select another day. Then repeat step 3.

5 Press **Mode** to exit the programming mode.

**NOTE:** If no button is pressed for 60 seconds, the thermostat will automatically exit the programming mode.

## 8 Power Outage

During a power outage, the settings are stored in memory. However, only the thermostat's clock must be re-adjusted if the power failure lasts more than 2 hours. When power comes back, the thermostat will return to the operating mode that was active prior to the power failure.

## 9 Troubleshooting

PROBLEM	SOLUTIONS
Thermostat is hot.	This condition is normal. Under normal operation, the thermostat housing can reach a temperature between 35°C (95°F) and 40°C (104°F).
Heater is always On.	The thermostat has not been correctly wired.
Thermostat indicates that heating is On, but the heater is not On.	The thermostat has not been correctly wired.
Wrong temperature is displayed.	The thermostat is exposed to air draft. Eliminate the draft. The sticker on the thermostat's screen has not been removed.
Wrong time is displayed.	The thermostat was without power for more than 2 hours.
Temperature does not change according to the programmed schedule.	Check that the thermostat is in Automatic mode. Check the schedule and clock settings.
Display disappears and reappears after a few minutes.	The thermal protection device on the heater is open. This can happen after a power failure or if the heater is obstructed by furniture or curtains.
Display looks faded when heating is activated	The heating system is less than the required minimum load. This thermostat cannot be used below that rating.

## 10 Technical Specifications

**Power:** 120/240 VAC, 50/60 Hz

**Minimum load:** 2 A (resistive only)  
500 W @ 240 VAC  
250 W @ 120 VAC

**Maximum load:** 16.7 A (resistive only)  
2000 W @ 120 VAC  
4000 W @ 240 VAC

**Display range:** 0°C to 60°C (32°F to 140°F)

**Display resolution:** 0.5°C (1°F)

**Setpoint range:** 5°C to 30°C (40°F to 86°F)

**Setpoint interval:** 0.5°C (1°F)

**Storage:** -20°C to 50°C (-4°F to 120°F)

**Approval:** c UL us

## Warranty

Aube warrants this product, excluding battery, to be free from defects in the workmanship or materials, under normal use and service, for a period of three (3) years from the date of purchase by the consumer. If at any time during the warranty period the product is determined to be defective or malfunctions, Aube shall repair or replace it (at Aube's option).

If the product is defective,

- (i) return it, with a bill of sale or other dated proof of purchase, to the place from which you purchased it, or
- (ii) contact Aube. Aube will make the determination whether the product should be returned, or whether a replacement product can be sent to you.

This warranty does not cover removal or reinstallation costs. This warranty shall not apply if it is shown by Aube that the defect or malfunction was caused by damage which occurred while the product was in the possession of a consumer.

Aube's sole responsibility shall be to repair or replace the product within the terms stated above. AUBE SHALL NOT BE LIABLE FOR ANY LOSS OR DAMAGE OF ANY KIND, INCLUDING ANY INCIDENTAL OR CONSEQUENTIAL DAMAGES RESULTING, DIRECTLY OR INDIRECTLY, FROM ANY BREACH OF ANY WARRANTY, EXPRESS OR IMPLIED, OR ANY OTHER FAILURE OF THIS PRODUCT. Some provinces and states do not allow the exclusion or limitation of incidental or consequential damages, so this limitation may not apply to you.

THIS WARRANTY IS THE ONLY EXPRESS WARRANTY AUBE MAKES ON THIS PRODUCT. THE DURATION OF ANY IMPLIED WARRANTIES, INCLUDING THE WARRANTIES OF MERCHANTABILITY AND FITNESS FOR A PARTICULAR PURPOSE, IS HEREBY LIMITED TO THE THREE-YEAR DURATION OF THIS WARRANTY. Some provinces and states do not allow limitations on how long an implied warranty lasts, so the above limitation may not apply to you.

This warranty gives you specific legal rights, and you may have other rights which vary from province or state to another.

## Customer Assistance

If you have any questions about the product installation or operation, or concerning the warranty, contact us at:

705 Montrichard  
Saint-Jean-sur-Richelieu, Quebec  
J2X 5K8  
Canada  
Tel.: (450) 358-4600  
Toll-free: 1-800-831-AUBE  
Fax: (450) 358-4650  
Email: aube.service@honeywell.com

For more information on our products, go to  
[www.aubetech.com](http://www.aubetech.com)



As an ENERGY STAR® partner, Aube Technologies has determined that this product meets the ENERGY STAR guidelines for energy efficiency.



# LED T8 | T12

Notify Me when Available

[Large Project? Click here to get a volume quote.](#)



## DESCRIPTION

## SPECIFICATIONS

## REVIEWS

### EarthLED Total Product Insight

#### PERFORMANCE SPECIFICATIONS

REPLACEMENT FOR:	T8 OR T12 4 FOOT FLUORESCENT TUBE
BRIGHTNESS (LUMENS):	2000
COLOR TEMPERATURE:	4000K   5000K
COLOR ACCURACY (CRI):	80
DIMENSIONS	1.02" X 47.2"
POWER CONSUMPTION:	18 WATTS
VOLTAGE:	120-277 VOLTS
DIMMABLE:	NO

#### DIMENSIONS / ADDITIONAL DATA

CERTIFICATIONS:	UL, DESIGNLIGHTS (DLC)
PRODUCT/ORDER CODE:	4000K - 18WT8P-4F-40K-BYP 5000K - 18WT8P-4F-50K-BYP

#### LIFESPAN / COST TO RUN

PROJECTED LIFE: @3 HRS/DAY	50,000 HRS
YEARLY ENERGY COST: 3 HRS/DAY @ .11 KWH	\$2.17

#### WARRANTY

5 YEAR THINKLUX LIGHTING LIMITED WARRANTY  
EARTHLED PRODUCT PROTECTION PLAN IS AVAILABLE

EarthLED Total Product Insight	
Performance Specifications	
REPLACEMENT FOR:	E12 CANDELABRA
BRIGHTNESS (LUMENS):	500
COLOR TEMPERATURE:	3000K   5000K
COLOR ACCURACY (CRI):	>80
TRADITIONAL WATTAGE EQUIVALENT:	60 WATTS
POWER CONSUMPTION:	7 WATTS
VOLTAGE:	120 VOLTS
DIMMABLE:	YES
MOISTURE RATING:	DAMP
FIXTURE RATING:	OPEN FIXTURES
BASE TYPE:	E12
ENERGYSTAR QUALIFIED:	YES (TKUCA38S01-7W-D-830-E12)
Dimensions / Additional Data	
BULB DIAMETER:	1.6 IN
MAXIMUM OVERALL LENGTH:	4.9 IN
PRODUCT WEIGHT:	6.7 OUNCES
CERTIFICATIONS:	UL
PRODUCT/ORDER CODE:	3000K - TKUCA38S01-7W-D-830-E12 5000K - TKUCA38S01-7W-D-850-E12
Lifespan / Cost To Run	
PROJECTED LIFE: @3 HRS/DAY	25,000 HRS
YEARLY ENERGY COST: 3 HRS/DAY @ .11 KWH	\$0.84
<b>WARRANTY</b>	3 YEAR THINKLUX LIMITED WARRANTY EARTHLED PRODUCT PROTECTION PLAN IS AVAILABLE



## FEATURES & SPECIFICATIONS

### INTENDED USE

Provides years of maintenance-free general illumination for outdoor use in commercial applications such as retail, education, multi-unit housing and storage. Ideal for lighting building facades, parking areas, walkways, garages, loading areas and any other outdoor space requiring reliable safety and security.

### CONSTRUCTION

Sturdy weather-resistant aluminum housing with a bronze finish, standard unless otherwise noted. A clear polycarbonate lens protects the optics from moisture, dirt and other contaminants.

### OPTICS

8 high performance LEDs are powered by a multi-volt (120V-277V) LED driver that uses 18 input watts and provides 1,490 delivered lumens. 100,000 hour LED lifespan based on IESNA LM-80-08 results and calculated per IESNA TM-21-11 methodology.

### ELECTRICAL

Rated for outdoor installations, -40°C minimum ambient.

Adjustable Dusk-to-dawn, multi-volt photocell standard automatically turns light on at dusk and off at dawn for convenience and energy savings.

Photocell can be disabled by rotating the photocell cover.

6KV

Surface or recessed mount. A universal junction box is included standard.

All mounting hardware included.

### LISTINGS

UL Certified to US and Canadian safety standards. Wet location listed for mounting higher than 4 feet off the ground.

Tested in accordance with IESNA LM-79 and LM-80 standards.

### WARRANTY

5-year limited warranty. Complete warranty terms located at

[www.acuitybrands.com/CustomerResources/Terms\\_and\\_conditions.aspx](http://www.acuitybrands.com/CustomerResources/Terms_and_conditions.aspx)

Actual performance may differ as a result of end-user environment and application.

Note: Specifications subject to change without notice.

Catalog Number
Notes
Type

Outdoor General Purpose

# OLW14

LED WALL PACK

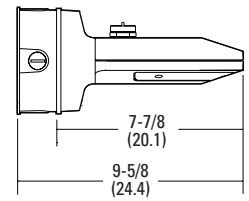
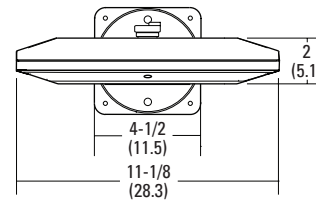

All dimensions are inches (centimeters) unless otherwise indicated.

### ORDERING INFORMATION

For shortest lead times, configure product using **bolded options**.

Example: OLW14

OLW14					
Series		Color temperature (CCT) <sup>1</sup>	Voltage	Control	Finish
<b>OLW14</b> 1400 lumen LED wall pack		<b>(blank)</b> 5000K <sup>1</sup>	<b>(blank)</b> MVOLT (120V-277V)	<b>(blank)</b> MVOLT photocell included	<b>(blank)</b> Bronze WH White

<b>Accessories:</b> Order as separate catalog number.	
FCOS M24	Full cutoff shield
FCOS WH M24	Full cutoff shield, white

### Notes

<sup>1</sup> Correlated Color Temperature (CCT) shown is nominal per ANSI C78,377-2008.

# OLW14 LED Wall Pack

## PHOTOMETRIC DIAGRAMS

Full photometric data report available within 2 weeks from request. Consult factory. Tested in accordance with IESNA LM-79 and LM-80 standards.

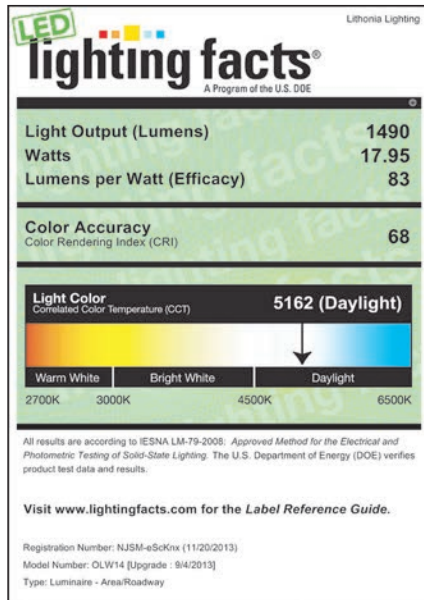



## Value and versatility defined

Our new “traditional-style” LED luminaires offer the shapes you’ve grown accustomed to coupled with the high-powered, energy-efficient LEDs you want.

This fixture was designed to fit seamlessly — eliminating unwanted markings from the removal of older fixtures. **Replace one or replace them all, either case, with energy-savings of up to 80%, Lithonia has you covered!**



TWS LED 1 replaces up to **70W HPS**



# Value and versatility defined

www.lithonia.com



Mounts to a recessed junction box — **lower mounting height, 7-10 feet**

## Product Dimensions

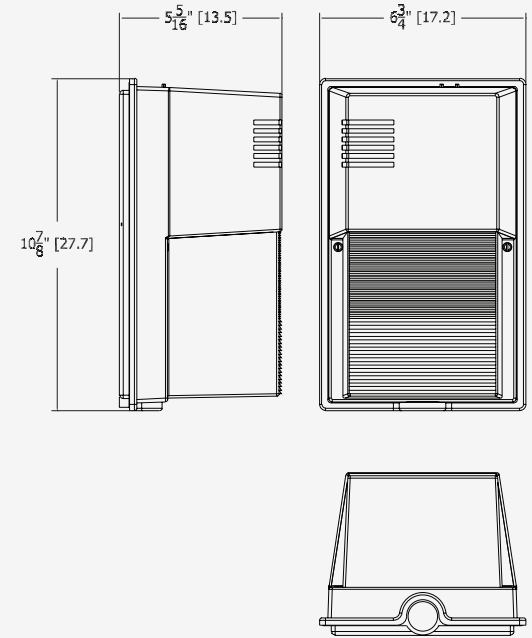

- **Impact resistant polycarbonate lens** provides an **even light distribution** and protects electronics
- 100,000 hour LED life<sup>1</sup>
- Includes standard photo cell for dusk to dawn operation
- **Cast aluminum back plate** dissipates heat from LEDs to promote long life
- Highly efficient LEDs provide **54 lumens per watt**

<sup>1</sup> LED lifespan based on IESNA LM-80-08 results and calculated per IESNA TM-21-11 methodology.

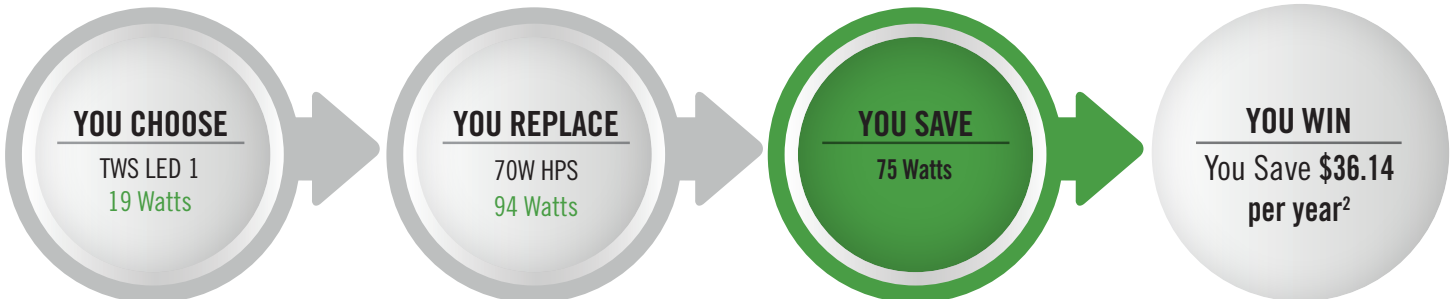

<sup>2</sup>Based on 12 hours operation per day and energy costs of \$.11 per kWh

### ORDERING INFORMATION

Lead times will vary depending on options selected. Consult with your sales representative.

Example: TWS LED 1 50K 120 PE

Series		Performance Package	Color Temperature (CCT)	Voltage	Control Options	Finish
<b>TWS LED</b>	LED Wall Pack	1 1017 lumens	<b>50K</b> 5000K <sup>3</sup>	<b>120</b> 120 volts	<b>PE</b> Photoelectric Cell, Button Type	<b>(blank)</b> Dark Bronze



### Notes

<sup>3</sup> Correlated Color Temperature (CCT) shown is nominal per ANSI C78,377-2008.

Catalog Number
Notes
Type

## FEATURES & SPECIFICATIONS

**INTENDED USE** — The OLFL provides years of maintenance-free general illumination for residential or commercial outdoor applications such as yards, driveways, patios, loading areas and warehouses.

**CONSTRUCTION** — Dusk-to-dawn photocell automatically turns on at dusk and off at dawn for convenience and energy savings.

Rugged cast-aluminum, corrosion-resistant housing in bronze finish.

Tempered glass lens is fully gasketed to protect LEDs and keep out moisture, dirt and bugs.

120V driver operates at 60 Hz, 0.258 amps, 25 watts.

Rated for outdoor installations, -40°C minimum ambient.

**OPTICS** — High-performance LEDs produce 1900 lumens and maintain 70% of light output at 50,000 hours of service. (LED lifespan based on IESNA LM-80-08 results and calculated per IESNA TM-21-11 methodology.)

Precision optics and reflector for maximum light output.

See Lighting Facts Labels for specific fixture performance.

**INSTALLATION** — Mounts easily to existing junction box on wall or under eave.

Adjustable head allows precise illumination.

**LISTINGS** — UL Listed to US and Canadian safety standards for wet locations. ENERGY STAR® certified product.

**WARRANTY** — 5-year limited warranty. Complete warranty terms located at: [www.acuitybrands.com/CustomerResources/Terms\\_and\\_conditions.aspx](http://www.acuitybrands.com/CustomerResources/Terms_and_conditions.aspx)

**Note:** Actual performance may differ as a result of end-user environment and application.

All values are design or typical values, measured under laboratory conditions at 25 °C.

Specifications subject to change without notice.

Outdoor General Purpose

# OLFL

LED FLOODLIGHT

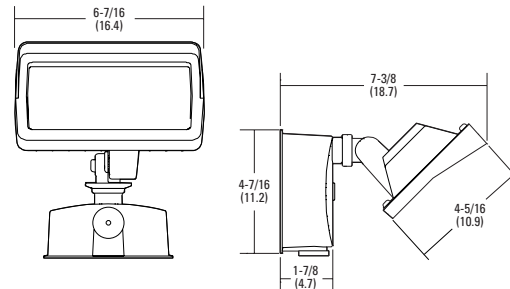

All dimensions are inches (centimeters) unless otherwise indicated.

### ORDERING INFORMATION

All configurations of this product are considered "standard" and have short lead times.

Example: OLFL 14 PE BZ

OLFL Series	14 Model / Color temperature (CCT) <sup>1</sup>	Voltage	PE Control	BZ Finish
OLFL	14 4000K	(blank) 120V	PE Button photocell	BZ Bronze

#### Notes

1 Nominal Correlated Color Temperature (CCT) per ANSI C78.377-2008.

# OLFL LED Floodlight

## PHOTOMETRIC DIAGRAMS

To see complete photometric reports or download .ies files for this product, visit the OLFL home page on [www.Lithonia.com](http://www.Lithonia.com). Tested in accordance with IESNA LM 79 and LM 80 standards. Actual wattage may differ by +/- 8% when operating between 120V +/- 10%.

### OLFL 14

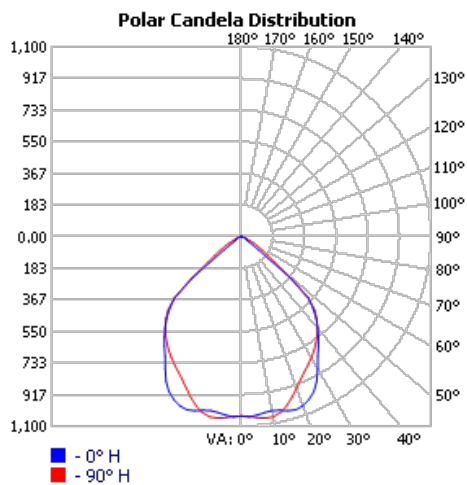
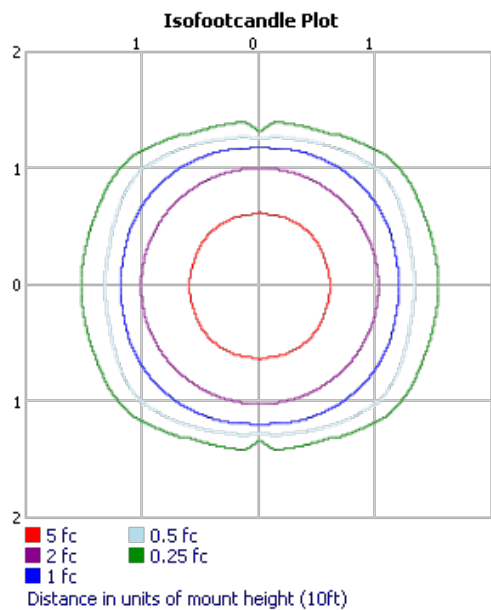

Lithonia Lighting

**LED lighting facts**  
A Program of the U.S. DOE

<b>Light Output (Lumens)</b>	<b>1900</b>
<b>Watts</b>	<b>25.4</b>
<b>Lumens per Watt (Efficacy)</b>	<b>74.8</b>

---

**Color Accuracy**  
Color Rendering Index (CRI) **70**

---

**Light Color**  
Correlated Color Temperature (CCT) **4000 (Bright White)**

2700K   3000K   4500K   6500K

All results are according to IESNA LM-79-2008: Approved Method for the Electrical and Photometric Testing of Solid-State Lighting. The U.S. Department of Energy (DOE) verifies product test data and results.

Visit [www.lightingfacts.com](http://www.lightingfacts.com) for the Label Reference Guide.

Registration Number: NJSM-146V3H (4/27/2016)  
Model Number: OLFL 14 PE XX upgraded 05/2016  
Type: Luminaire - Area/Roadway