



Comprehensive Energy Audit For

Manokotak Village Council Building



Prepared For
Manokotak Village Council

May 15, 2018

Prepared By: Kevin Ulrich, CEM

**ANTHC-DEHE
4500 Diplomacy Dr.
Anchorage, AK 99508**

Table of Contents

PREFACE	2
ACKNOWLEDGMENTS.....	2
OVERVIEW.....	3
ENERGY BASELINE	3
PROPOSED ENERGY EFFICIENCY MEASURES (EEM).....	3
FACILITY DESCRIPTION	4
PROJECT FINANCING.....	6
MEASUREMENT AND VERIFICATION	6
Appendix A –Energy Billing Data.....	7
Appendix B – Energy Audit Report – Project Summary.....	8
Appendix C – Actual Fuel Use versus Modeled Fuel Use.....	9
Appendix D - EUI Calculation Details	10
Appendix E – Materials List and Labor Estimation.....	11
Appendix F – Materials Specifications	12

PREFACE

The purpose of this report is to provide guidance in reducing facility operating costs and enhance the sustainability of this community. The report assesses the current energy usage of the facility, provide options for reducing the amount of energy used, and evaluate the cost vs. benefit of each option.

Discussions of site specific concerns, financing options, general facility information, and an Energy Efficiency Action Plan are also included in this report.

ACKNOWLEDGMENTS

The Rural Energy Initiative gratefully acknowledges the assistance of the staff and faculty at the Manokotak Village Council Building.

OVERVIEW

This report was prepared for the Manokotak Village Council. The scope of the audit focused on the Manokotak Village Council Building and includes an analysis of building occupancy schedules, building shell, heating systems, heating and ventilations systems, domestic hot water, lighting, and other electrical loads. The Manokotak Village Council Building is a wood-framed building built on an elevated pile foundation and is approximately 2,562 square feet in area. The building serves as office space for the Manokotak Village Council and also has a large common room used for council meetings.

Annual Energy Costs by Fuel Type

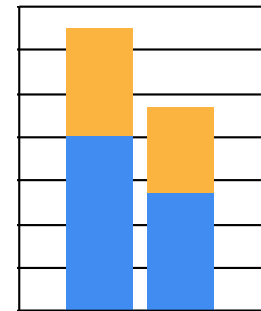

ENERGY BASELINE

Based on unsubsidized electricity and fuel oil prices in effect at the time of the audit, the total predicted energy costs are \$12,989 per year. This includes \$8,056 for unsubsidized electricity and \$4,933 for #1 fuel oil.

The State of Alaska Power Cost Equalization (PCE) program provides a subsidy to rural communities across the state to lower electricity costs and make energy affordable in rural Alaska. In Manokotak the cost of electricity without PCE is \$0.57/kWh and the cost of electricity with PCE is \$0.27/kWh. With the PCE subsidy, the electric utility cost to the Manokotak Village Council is \$3,816 and the cost to the State of Alaska is \$4,240.

Table 1 lists the predicted annual energy usage before and after the proposed retrofits for the Manokotak Village Council Building.

Table 1: Predicted Annual Energy Use for the Manokotak Village Council Building

Predicted Annual Fuel Use				
Fuel Use	Existing Building	With Proposed Retrofits	Total Energy Savings	Total Cost Savings (Subsidized)
Electricity	14,647 kWh	9,832 kWh	4815 kWh	\$1,300
#1 Oil	1,096 gallons	886 gallons	210 gallons	\$840

PROPOSED ENERGY EFFICIENCY MEASURES (EEM)

Table 2 below summarizes the energy efficiency measures analyzed for the Manokotak Village Council Building. Listed are the estimates of the annual savings, installed costs, and two different financial measures of investment return. All costs assume that local labor will be used with no additional cost associated for travel or administrative tasks.

Table 2: Priority List – Energy Efficiency Measures

Priority	Feature	Improvement Description	Annual Energy Savings	Installed Cost	Savings to Investment Ratio, SIR ¹	Simple Payback (Years) ²	CO ₂ Savings
High	Setback Thermostat: Office Building	Implement a Heating Temperature Unoccupied Setback to 60.0 deg F for the Office Building space.	\$1,245	\$1,000	16.83	0.8	5,850.3
High	Other: Small Electric Heaters (8)	Reduce electric heater runtimes.	\$2,175	\$2,000	9.00	0.9	10,752.3
Medium	Other Electrical: Bunn Coffee Pot - Single Pot	Unplug coffee pot in the evenings when not in use.	\$85	\$250	2.88	2.9	419.7
Low	Heating and Domestic Hot Water	Clean and tune boilers.	\$87	\$2,000	0.75	23.1	406.6
TOTAL			\$3,592	\$5,250	7.06	1.5	17,428.8

FACILITY DESCRIPTION

Building Occupancy Schedules

The building is occupied from 9:00 AM – 5:00 PM for five days per week during standard office hours for use by the village council. There is a large gathering area that is used for village council meetings and similar events periodically in the evenings.

Building Shell

The building is a wood-framed lumber construction that is built on an elevated pile foundation. The roof has 2x6 lumber construction with an attic in the roof.

There are 16 total windows in the building. Each window has triple-pane glass with aluminum framing and is approximately 34" x 58" in dimension. One of the windows has been boarded up because of broken glass and one of the windows is facing in the southern direction.

There are three total entrances to the building. All of the entrances are single wood doors with half-lite windows.

Heating Systems

The heating systems used in the building are:

Burnham V8H3

Fuel Type:	#1 Oil
Input Rating:	109,000 BTU/hr
Steady State Efficiency:	78 %
Idle Loss:	1.5 %

Heat Distribution Type: Glycol
 Boiler Operation: All Year

Oil Miser 122DW Hot Water Heater

Fuel Type: #1 Oil
 Input Rating: 148,000 BTU/hr
 Steady State Efficiency: 95 %
 Idle Loss: 0 %
 Heat Distribution Type: Water
 Boiler Operation: All Year

Space Heating Distribution Systems

Space heating is achieved through a baseboard distribution system that transports heated glycol throughout the building to disperse the heat through baseboard units.

Domestic Hot Water System

There is a restroom and kitchen in the office that use hot water during the day. The kitchen is used for the staff during the work day and for special events. There is a sink in the kitchen and a sink in the restroom.

Lighting

Table 3: Lighting Information in the Manokotak Village Council Building

Room	Bulb Type	Fixtures	Bulbs per Fixture	Annual Usage (kWh)
Office Building – Small Fixtures	LED Panels – 17W	23	1	1,019
Office Building – Big Fixtures	LED Panels – 25W	4	1	254

Other Electrical Loads

There is a variety of office equipment and phones that are used during the day that use a small amount of energy throughout the year.

Major Equipment

Table 4: Major Electrical Equipment in the Manokotak Village Council Building

Equipment	Rating (Watts)	Annual Usage (kWh)
Desktop Computers (11)	~ 150 each	3,444
Small Printers (8)	~ 75 each	42
Coffee Pot	900	351

Electric Stove	1,500	196
Microwave	1,200	78
Refrigerator	46	400
Small Electric Heaters (8)	~ 1,500 each	8,653

PROJECT FINANCING

The total estimated cost of the recommended EEM’s \$5,250. The payback for the implemented EEM’s is approximately 1.5 years. ANTHC is willing to assist the community with acquiring funds to complete the scope of work recommended in this energy audit.

There are several options for financing energy efficiency projects within the State of Alaska. These include the use of grants, loans, and other funding opportunities. Below is some information on potential funding opportunities.

Energy Efficiency Revolving Loan Program – This is a loan administered by the Alaska Housing Finance Corporation (AHFC) for use by any applicant who is also the owner of the building where the work will take place. It provides a loan for permanent energy-efficiency projects with a completion window of one year.

Sustainable Energy Transmission and Supply Program – This is a loan administered by the Alaska Energy Authority (AEA) for a government, business, or other organized body of people. It provides a loan for energy-efficiency or power transmission or distribution projects.

USDA-RD Communities Facilities Direct Loan & Grant Program - This is a loan or grant provided by the US Department of Agriculture – Rural Development (USDA-RD) for any essential community facility in a rural area. It provides a loan or grant to develop essential community facilities with upgrades or equipment for improvement.

MEASUREMENT AND VERIFICATION

The results of these recommended measures can be measured through the collection of energy use data through the monthly bills provided by the local electric utility and the local fuel oil supplier. Collecting data and performing a historical comparison is the simplest method of validating the energy and cost savings seen by the measures. Additionally, active remote monitoring systems are available that can collect and store data regarding energy and fuel usage. These systems allow the user to track the usage in real time and can be shared more easily with partners across the state.

APPENDICES

Appendix A –Energy Billing Data

The table below shows the fuel and electricity data used during the energy modeling process to confirm the accuracy of the energy distribution. The fuel use distribution was estimated based on the times of each fuel delivery, which were not in a precisely monthly basis.

Month	Fuel Oil Use (gallons)	Electricity Use (kWh)
January	130	Not Received
February	120	Not Received
March	110	Not Received
April	100	Not Received
May	60	Not Received
June	35	Not Received
July	35	Not Received
August	35	Not Received
September	60	Not Received
October	75	Not Received
November	110	Not Received
December	130	Not Received

Appendix B – Energy Audit Report – Project Summary

ENERGY AUDIT REPORT – PROJECT SUMMARY	
General Project Information	
PROJECT INFORMATION	AUDITOR INFORMATION
Building: Manokotak Village Council Building	Auditor Company: ANTHC-DEHE
Address: Manokotak	Auditor Name: Kevin Ulrich
City: Manokotak	Auditor Address: 4500 Diplomacy Dr.
Client Name: Barbara Palvin	Anchorage, AK 99508
Client Address:	Auditor Phone: (907) 729-3237
Client Phone: (907) 289-2067	Auditor FAX:
Client FAX:	Auditor Comment:
Design Data	
Building Area: 2,562 square feet	Design Space Heating Load: Design Loss at Space: 10,284 Btu/hour with Distribution Losses: 10,284 Btu/hour Plant Input Rating assuming 82.0% Plant Efficiency and 25% Safety Margin: 15,677 Btu/hour Note: Additional Capacity should be added for DHW and other plant loads, if served.
Typical Occupancy: 0 people	Design Indoor Temperature: 72 deg F (building average)
Actual City: Manokotak	Design Outdoor Temperature: -17.2 deg F
Weather/Fuel City: Manokotak	Heating Degree Days: 10,828 deg F-days
Utility Information	
Electric Utility: Manokotak Power Company	Average Annual Cost/kWh: \$0.57/kWh

Annual Energy Cost Estimate						
Description	Space Heating	Water Heating	Lighting	Refrigeration	Other Electrical	Total Cost
Existing Building	\$4,868	\$181	\$700	\$220	\$7,020	\$12,989
With Proposed Retrofits	\$3,900	\$181	\$700	\$220	\$4,396	\$9,397
Savings	\$968	\$0	\$0	\$0	\$2,624	\$3,592

Building Benchmarks			
Description	EUI (kBtu/Sq.Ft.)	EUI/HDD (Btu/Sq.Ft./HDD)	ECI (\$/Sq.Ft.)
Existing Building	76.0	7.02	\$5.07
With Proposed Retrofits	58.8	5.43	\$3.67

EUI: Energy Use Intensity - The annual site energy consumption divided by the structure's conditioned area.
 EUI/HDD: Energy Use Intensity per Heating Degree Day.
 ECI: Energy Cost Index - The total annual cost of energy divided by the square footage of the conditioned space in the building.

Appendix C – Actual Fuel Use versus Modeled Fuel Use

The graphs below show the modeled energy usage results of the energy audit process compared to the actual energy usage report data. The model was completed using AkWarm modeling software. The orange bars show actual fuel use, and the blue bars are AkWarm’s prediction of fuel use.

Annual Energy Use

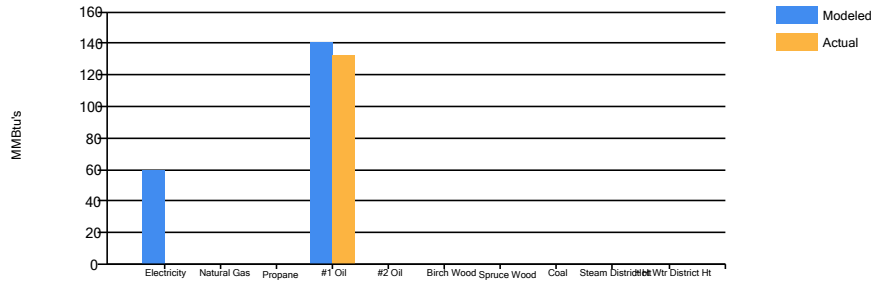

Electricity Use

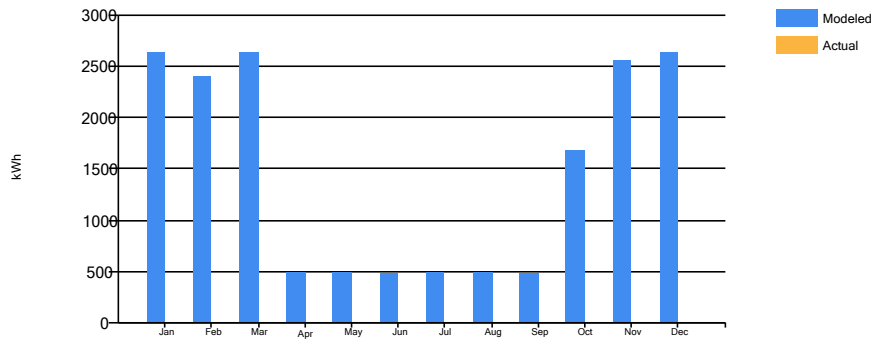

#1 Fuel Oil Use

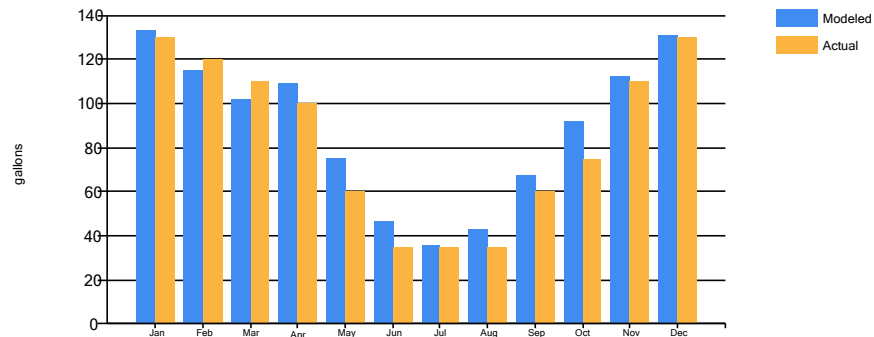

Appendix D - EUI Calculation Details

The Manokotak Power Company owns and operates the utility that provides electricity to the residents of the community as well as to all the commercial and public facilities.

The average cost for each type of fuel used in this building is shown below in Table 5. This figure includes all surcharges, subsidies, and utility customer charges:

Table 5: Energy Cost Rates for each Fuel Type.

Average Energy Cost	
Description	Average Energy Cost
Electricity	\$ 0.57/kWh
#1 Oil	\$ 4.50/gallons

Table 6 shows the calculated results for the building Energy Use Index (EUI), which determines the total energy usage for a type of building for comparison with other buildings of the same type. This allows the user to determine the relative energy use of a building in relation to others of the same type or use.

Table 6: EUI Building Calculations for the Manokotak Village Council Building

Energy Type	Building Fuel Use per Year	Site Energy Use per Year, kBTU	Source/Site Ratio	Source Energy Use per Year, kBTU
Electricity	17,523 kWh	59,806	3.340	199,753
#1 Oil	1,061 gallons	140,003	1.010	141,403
Total		199,809		341,156
BUILDING AREA		2,562	Square Feet	
BUILDING SITE EUI		78	kBTU/Ft ² /Yr	
BUILDING SOURCE EUI		133	kBTU/Ft²/Yr	
* Site - Source Ratio data is provided by the Energy Star Performance Rating Methodology for Incorporating Source Energy Use document issued March 2011.				

Table 7 shows information on common energy use benchmarks used to characterize the efficiency of a building.

Table 7: Building Benchmarks for the Manokotak Village Council Building

Building Benchmarks			
Description	EUI (kBtu/Sq.Ft.)	EUI/HDD (Btu/Sq.Ft./HDD)	ECI (\$/Sq.Ft.)
Existing Building	76.0	7.02	\$5.07
With Proposed Retrofits	58.8	5.43	\$3.67
EUI: Energy Use Intensity - The annual site energy consumption divided by the structure's conditioned area. EUI/HDD: Energy Use Intensity per Heating Degree Day. ECI: Energy Cost Index - The total annual cost of energy divided by the square footage of the conditioned space in the building.			

Appendix E – Materials List and Labor Estimation

Table 8 & 9: Materials List and Cost Estimation for Manokotak Village Council EEM's

Energy Retrofit	Required Materials	Quantity	Cost per Item	Total Materials Cost
Setback Thermostat	Programmable Thermostat	1	150	150
Boiler Tuning	Tigerloop, fuel meter	1	400	400

Category	Cost (\$)
Labor	2596
Travel	1530
Materials	550
Freight	83
Indirect	476
Total	5234

This energy audit cost information assumes that all work will be completed by an employee from outside of the community. If local labor is used for the retrofits, the travel and indirect costs may be removed from the total estimated cost. The boiler cleaning and setback thermostat retrofits will likely require outside labor.

Appendix F – Materials Specifications

Robertshaw®

9701i2

DELUXE
PROGRAMMABLE
THERMOSTAT



GAS



ELECTRIC



OIL



HEAT PUMP

Menu Driven Display 1 Heat / 1 Cool

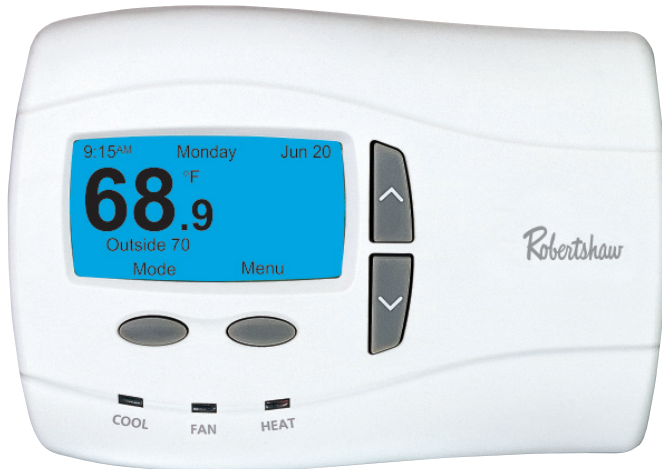

Programming Made Even Easier

Do you want to spend less time installing and setting up thermostats?

The new 9701i2 makes installation even easier with our new Setup Wizard. The Setup Wizard allows you to spend 50% less time setting up the thermostat over competitive models. Plus everything is in plain language so there are no complicated codes or button combinations to memorize.

We've also made programming even easier for your customers. Menus are easier to navigate. We've even added additional convenience features such as Automated Time adjustment for Daylight Saving Time, along with new indoor air quality reminders.

The new 9701i2 is so user friendly, it sets a higher standard in efficiency and simplicity for programmable thermostats. It is truly programming made even easier.

Robertshaw - *Simply the Right Choice™*

Features and Benefits

Would You Like To Run the Setup Wizard?

No Yes

Set-up Wizard

Helps speed through the installation process with step-by-step setup and programming instructions.

Select Language

English
Español
Français

Back Next

Trilingual Display Option

Set to your customers' language of choice – English, Spanish or French

Mon To Sun Program

		HEAT	COOL
Wake	6:00 AM	70	78
Morn	8:00 AM	62	65
Eve	5:00 PM	70	78
Night	10:00 PM	62	62
Exit		Select	

Convenient Displays

View a full day of programming at once for quick review or easy adjustment.

Tech Support

Model 9701i vX.X
ABC HEAT
555-1234
ROBERTSHAW
(800) 445-8299

Contractor ID Feature

Set it yourself or custom order with your information pre loaded. Your name and phone number remind your customers when service is needed.

Daylight Saving Time Adjustment

Automatically adjusts to correct time regardless of seasonal changes.

Adjustable Backlighting

Choose to have backlighting on at all times or only when programming. You can also adjust the brightness and contrast for improved readability.

Time of Day Zoning

When coupled with a remote sensor (part #9020i), you can control the temperature in remote locations given different scheduled events.

Three Levels of Security

Secure protection against unwanted changes to the programming menus, temperature or set-up functions with your own 4-digit PIN.

Auto Changeover

Automatically adjusts between heating and cooling cycles to maintain optimal comfort.

Worry-Free Memory Storage

Even during power outages, the thermostat maintains set point and programmed parameters.

Adjustable Temperature Offset

Change the displayed temperature from the actual sensed temperature.

Adjustable Temperature Differential

Maintains optimal customer comfort.

Intermittent Fan

Maintains optimal air filtration and circulation with minimal energy use.

An ISO 9001 – 2008 Certified Company

California Title 24 Compliant



5 Year
Limited
Warranty

24V AC POWERED

Robertshaw®

9701i2 DELUXE PROGRAMMABLE THERMOSTAT

Terminal Designations

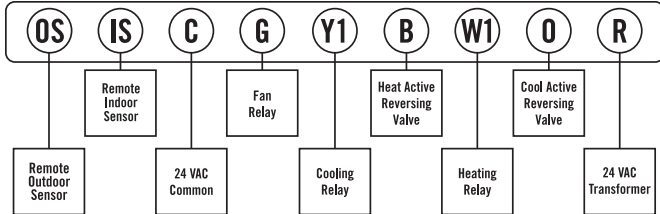

Technical Specifications

Electrical Rating	24 Volt AC (18-30 VAC) 1 amp maximum load per terminal (relay outputs) 3 amp total maximum load (all terminals combined)
Temperature Control Range	45°- 90°F (7°- 32°C)
Accuracy	+/-1.0°F (+/-0.5°C)
Power Source	24 VAC
Auto Changeover Deadband	Selectable 2° to 8°F
Temporary Temperature Override	3 hour maximum or next setpoint
Remote Sensor Capable	1 indoor and 1 outdoor sensor
System Configurations	Single-stage gas, oil or electric heating/cooling systems and single stage heat pump
Terminations	R, W1, Y1, B, O, G, C, IS, OS

Shipping Specifications

Indiv. Ctn. Dim.: 6.625" x 4.25" x 1.625"	Item 9020i and 9025i Remote Sensors
Master Ctn. Qty.: 6	Indiv. Ctn. Dim.: 2.625" x 1.5625" x 4.4375"
Master Ctn. Dim.: 9.25" x 5.625 x 7.5"	Master Ctn. Qty.: 6
Master Ctn. Cu. Ft.: .23	Master Ctn. Dim.: 5.625" x 5.125" x 5.125"
Master Ctn. Wt.: 3.5 lbs.	Master Ctn. Cu. Ft.: .09
Max. Pallet Qty.: 1260	Master Ctn. Wt.: .78 lbs.
Max. Pallet Wt.: 785 lbs.	

Replacement Chart

9701i2	
Braeburn®	5000
Honeywell	TH8110U1003
White-Rodgers	1F95-1271, 1F90-51, 1F90-71, 1F90-371, 1F97-51, 1F97-71, 1F97-371
Carrier	TC-PAC, TC-PHP, P274-1100, P374-1100, P474-1100
Lux	PSPA711

Verify specific application requirements before substitution.

Patent Information

This product is covered by one or more of the following U.S. patents. Foreign patent rights may be pending. 4967382, 5803357, 6502758, 7000849, D301207, D462940

invenSYS
Controls

191 E. North Avenue
Carol Stream Illinois 60188 USA
Customer Service Telephone 1.800.304.6563
Customer Service Facsimile 1.800.426.0804
HVACCustomerService@InvenSysControls.com

For Technical Service
Telephone 1.800.445.8299
Facsimile 1.630.260.7294
TechnicalService@InvenSysContrtols.com

InvenSys™, Robertshaw® and Simply the Right Choice™ are trademarks of InvenSys plc., its subsidiaries and/or affiliated companies. All other brands mentioned in this report may be the trademarks of their respective owners.

www.RobertshawTstats.com
www.InvenSysControls.com
©2009 InvenSys Controls 10/09 - 150-1978B



Optional Sensors:
9020i: REMOTE INDOOR
9025i: REMOTE OUTDOOR

Feature Comparison

	InvenSys i2-Series	Honeywell Vision Pro	Carrier Infinity	White-Rodgers 1F97-371
Menu Driven (Ease of Programming)	X			
Installation Wizard	X			
Displays Complete Program	X			
Adjustable Backlighting	X			
Cooling System Monitor	X			
Heating System Monitor	X			
Multi-Language	X			
1/2 Degree Resolution	X			
Time of Day Zoning	X			
5/2 Program	X			X
24 Hour Programming	X			X
7-Day Programming	X	X	X	
Large Display	X	X	X	
Adjustable Timed Override/Hold	X	X		
Automatic Daylight Saving Time Adjustment	X	X		
Adjustable Temperature Limits	X	X		
High/Low Balance Points	X	X		
LED Status Indicators	X	X		
Adjustable Differential	X	X		
Adjustable Compressor Short Cycle Protection	X	X		
Adjustable Residual Cooling	X	X		
Fossil Fuel Kit required on HP units	No	No	Yes	Yes
Battery Free Memory Retention	X		X	
Manual Override	X	X	X	X
Resume	X	X	X	X
Auto Changeover	X	X	X	X
Gas/Electric	X	X	X	X
Single Stage Heat Pump Compatible	X	X	X	X
Line Powered	X	X	X	X
Programmable Fan	X	X	X	X
Intermittent Fan	X		X	
°F and °C	X	X	X	X
12 or 24 Hour	X	X		X
Air Filter Monitor	X	X	X	X
Humidifier Pad Monitor	X	X	X	
UV Light Monitor	X	X	X	
Vacation Setting	X	X	X	X
O & B Terminals	X	X	Partial	X
Events per day	2, 4, 6	4	4	2, 4
Remote Outdoor Sensor	X	Combo	X	X
Remote Indoor Sensor	X		X	X
Energy Efficient Recovery	X	X	X	X
Pre-set Program	X	X	X	X
Hidden Service Level	X	X	X	
Security Key Pad	X			X
Temperature Recalibration	X	X	X	
Customizable Contractor ID	X			Factory Only

NOTE: Always keep the thermostat's vents clean and unobstructed.

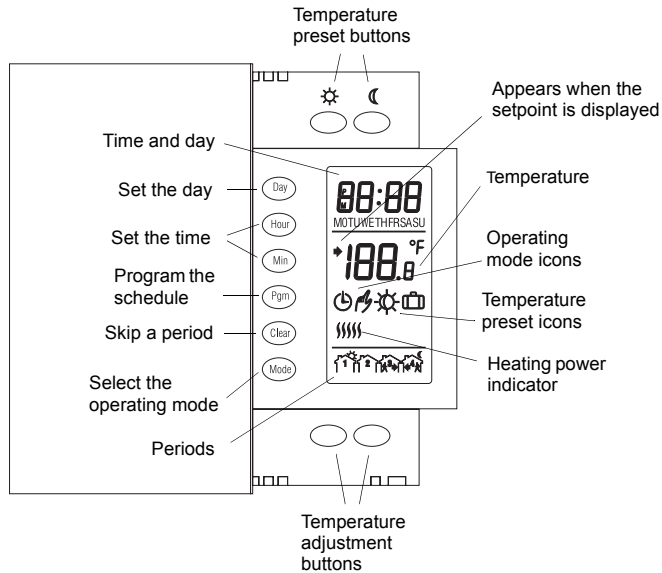

1 Description

This programmable thermostat can be used to control an electric heating system such as an electric baseboard heater, a radiant ceiling, a radiant floor, a convector, etc.

The thermostat cannot be used under the following conditions:

- The resistive load is greater than 16.7 A
- The resistive load is less than 2 A
- The system is driven by a contactor or relay (inductive load)
- The system is a central heating system

SUPPLIED PARTS:

- One (1) thermostat
- Two (2) 6-32 screws
- Two (2) solderless connectors

2 Installation

TURN OFF POWER TO THE HEATING SYSTEM AT THE MAIN POWER PANEL TO AVOID ELECTRICAL SHOCK.

THE INSTALLATION MUST BE PERFORMED BY AN ELECTRICIAN.

- ▶ All cables and connections must conform to the local electrical code.
- ▶ Special CO/ALR solderless connectors must be used when connecting with aluminum conductors.
- ▶ Install the thermostat onto an electrical box.
- ▶ Install the thermostat about 5 feet high, on an inside wall facing the heater.
- ▶ Avoid locations where there are air drafts (such as the top of a staircase or an air outlet), dead air spots (such as behind a door), or direct sunlight.
- ▶ Do not install the thermostat on a wall that conceals chimney or stove pipes.
- ▶ The thermostat wires are not polarized; either wire can be connected to the load or to the power supply.

1

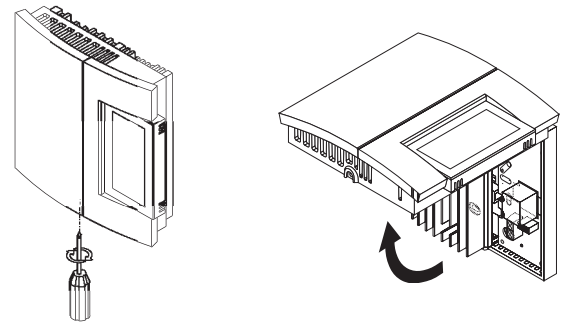

2 Connect the thermostat wires to the line wires and to the load wires using solderless connectors for copper wires.

2-wire installation

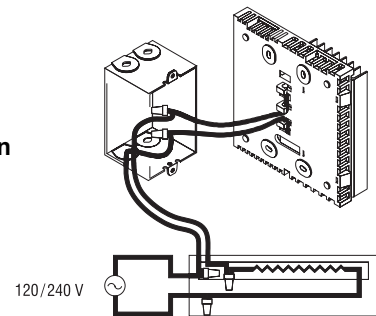

4-wire installation

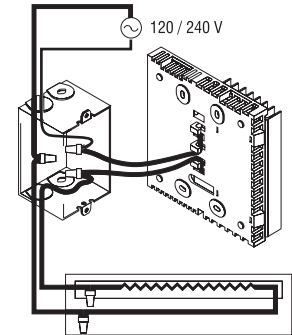

3 Push any excess wire back into the electrical box.

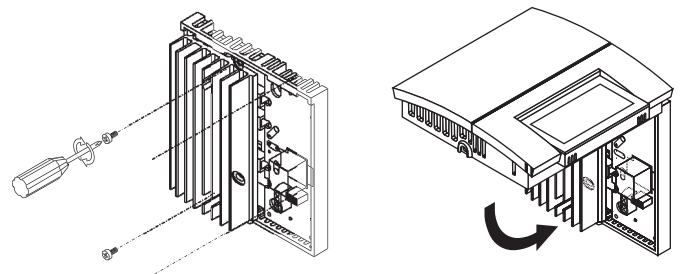

NOTE: If necessary, before re-installing the front component, configure the thermostat (see section 3).

4 Return power to heating system.

3 Configuration

The configuration switches are on the back of the thermostat. The factory settings are indicated by the gray cells in the following table.

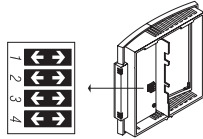

SW1	Early Start ^a	Off	On
SW2	Temperature / time format ^b	°C / 24-hour	°F / 12-hour
SW3	Cycle length ^c	15 seconds	15 minutes
SW4	Not used	-	-

- Early Start can be used in Automatic mode only. When this function is enabled, the thermostat calculates the optimal time to start heating in order to obtain the desired temperature by the set time. The thermostat re-assesses the start time daily based on the previous day's performance.
- If you change the temperature display format, the preset temperatures (☼, ☾ and ☰) will return to their default settings.
- 15-second cycles should be selected in most cases as it provides better temperature control. 15-minute cycles must be selected if you have a fan-equipped heater or if 15-second cycles causes light flickering (especially in rural regions).

4 Power-up

Upon power-up, the thermostat is in manual mode (☼) and displays the actual (ambient) temperature.

- Press the **Hour** and **Min** buttons to set the thermostat's clock.
- Press the **Day** button to set the day.

5 Temperature Setting

Setpoint

The thermostat normally displays the actual temperature. To view the setpoint, press the ▲ or ▼ button briefly. The setpoint will appear for the next 5 seconds.

To change the setpoint, press the ▲ or ▼ button until the desired temperature is displayed. To scroll faster, hold the button.

Using a preset temperature

The thermostat has 3 preset temperatures:

- Comfort temperature ☼
- Economy temperature ☾
- Vacation temperature ☰

Icon	Intended use	Factory setting
☼	Comfort (when at home)	21°C (70°F)
☾	Economy (when asleep or away from home)	16.5°C (62°F)
☰	Vacation (during prolonged absence)	10°C (50°F)

- To use the Comfort or Economy temperature, press the ☼ or ☾ button respectively. The corresponding icon will be displayed.
- To use the Vacation temperature, press both ☼ and ☾ buttons simultaneously. The ☰ icon will be displayed.

Storing a preset temperature

To store the Comfort or Economy temperature:

Set the desired temperature using the ▲ or ▼ button. Press and hold the appropriate button (☼ or ☾) for approximately 3 seconds until the corresponding icon is displayed. Press the **Mode** button.

To store the Vacation temperature:

Set the desired temperature using the ▲ or ▼ button. Press and hold both ☼ and ☾ buttons simultaneously for approximately 3 seconds until the ☰ icon is displayed. Press the **Mode** button.

6 Operating Modes

⌚ **Automatic** - The temperature is set according to the programmed schedule. To place the thermostat in this mode, press **Mode** until ⌚ is displayed. The icons of the current period and preset temperature are also displayed.

Temporary Bypass: If you modify the setpoint (by pressing the ▲, ▼, ☼ or ☾ button) when the thermostat is in automatic mode, the new setpoint will be used until the end of the current period. When the next period starts, the temperature set for that period becomes the new setpoint.

☼ **Manual** - The programmed schedule is not used. The temperature must be set manually. To place the thermostat in this mode:

- Press **Mode** until ☼ is displayed.
- Set the temperature using the ▲, ▼, ☼ or ☾ button.

7 Schedule

The schedule consists of 4 periods per day which represents a typical weekday. You can program the thermostat to skip the periods that do not apply to your situation. For example, you can skip periods 2 and 3 for the weekend.

Period	Description	Associated temperature preset
☼	Wake	☼
☾	Leave	☾
☼	Return	☼
☾	Sleep	☾

The Comfort (☼) temperature is used in periods 1 and 3 and the Economy (☾) temperature is used in periods 2 and 4. For example, when the period changes from 1 to 2, the setpoint automatically changes from Comfort setting (☼) to Economy setting (☾).

You can have a different program for each day of the week; i.e., each period can start at different time for each day of the week. The thermostat has been programmed with the following schedule.

Period	Setting	MO	TU	WE	TH	FR	SA	SU
☼	☼	6:00 AM	6:00 AM	6:00 AM	6:00 AM	6:00 AM	6:00 AM	6:00 AM
☾	☾	8:00 AM	8:00 AM	8:00 AM	8:00 AM	8:00 AM	--:--	--:--
☼	☼	6:00 PM	6:00 PM	6:00 PM	6:00 PM	6:00 PM	--:--	--:--
☾	☾	10:00 PM	10:00 PM	10:00 PM	10:00 PM	10:00 PM	10:00 PM	10:00 PM

To modify the schedule:

- Press **Pgm** to access the programming mode. Period 1 is selected.
- Press **Day** to select the day to program (hold for 3 seconds to select the entire week).
- Press **Hour** and **Min** to set the start time of the selected period, or press **Clear** if you want to skip the period (--:-- is displayed).
- Press **Pgm** to select another period, or press **Day** to select another day. Then repeat step 3.

5 Press **Mode** to exit the programming mode.

NOTE: If no button is pressed for 60 seconds, the thermostat will automatically exit the programming mode.

8 Power Outage

During a power outage, the settings are stored in memory. However, only the thermostat's clock must be re-adjusted if the power failure lasts more than 2 hours. When power comes back, the thermostat will return to the operating mode that was active prior to the power failure.

9 Troubleshooting

PROBLEM	SOLUTIONS
Thermostat is hot.	This condition is normal. Under normal operation, the thermostat housing can reach a temperature between 35°C (95°F) and 40°C (104°F).
Heater is always On.	The thermostat has not been correctly wired.
Thermostat indicates that heating is On, but the heater is not On.	The thermostat has not been correctly wired.
Wrong temperature is displayed.	The thermostat is exposed to air draft. Eliminate the draft. The sticker on the thermostat's screen has not been removed.
Wrong time is displayed.	The thermostat was without power for more than 2 hours.
Temperature does not change according to the programmed schedule.	Check that the thermostat is in Automatic mode. Check the schedule and clock settings.
Display disappears and reappears after a few minutes.	The thermal protection device on the heater is open. This can happen after a power failure or if the heater is obstructed by furniture or curtains.
Display looks faded when heating is activated	The heating system is less than the required minimum load. This thermostat cannot be used below that rating.

10 Technical Specifications

Power: 120/240 VAC, 50/60 Hz

Minimum load: 2 A (resistive only)
500 W @ 240 VAC
250 W @ 120 VAC

Maximum load: 16.7 A (resistive only)
2000 W @ 120 VAC
4000 W @ 240 VAC

Display range: 0°C to 60°C (32°F to 140°F)

Display resolution: 0.5°C (1°F)

Setpoint range: 5°C to 30°C (40°F to 86°F)

Setpoint interval: 0.5°C (1°F)

Storage: -20°C to 50°C (-4°F to 120°F)

Approval: c UL us

Warranty

Aube warrants this product, excluding battery, to be free from defects in the workmanship or materials, under normal use and service, for a period of three (3) years from the date of purchase by the consumer. If at any time during the warranty period the product is determined to be defective or malfunctions, Aube shall repair or replace it (at Aube's option).

If the product is defective,

- (i) return it, with a bill of sale or other dated proof of purchase, to the place from which you purchased it, or
- (ii) contact Aube. Aube will make the determination whether the product should be returned, or whether a replacement product can be sent to you.

This warranty does not cover removal or reinstallation costs. This warranty shall not apply if it is shown by Aube that the defect or malfunction was caused by damage which occurred while the product was in the possession of a consumer.

Aube's sole responsibility shall be to repair or replace the product within the terms stated above. AUBE SHALL NOT BE LIABLE FOR ANY LOSS OR DAMAGE OF ANY KIND, INCLUDING ANY INCIDENTAL OR CONSEQUENTIAL DAMAGES RESULTING, DIRECTLY OR INDIRECTLY, FROM ANY BREACH OF ANY WARRANTY, EXPRESS OR IMPLIED, OR ANY OTHER FAILURE OF THIS PRODUCT. Some provinces and states do not allow the exclusion or limitation of incidental or consequential damages, so this limitation may not apply to you.

THIS WARRANTY IS THE ONLY EXPRESS WARRANTY AUBE MAKES ON THIS PRODUCT. THE DURATION OF ANY IMPLIED WARRANTIES, INCLUDING THE WARRANTIES OF MERCHANTABILITY AND FITNESS FOR A PARTICULAR PURPOSE, IS HEREBY LIMITED TO THE THREE-YEAR DURATION OF THIS WARRANTY. Some provinces and states do not allow limitations on how long an implied warranty lasts, so the above limitation may not apply to you.

This warranty gives you specific legal rights, and you may have other rights which vary from province or state to another.

Customer Assistance

If you have any questions about the product installation or operation, or concerning the warranty, contact us at:

705 Montrichard
Saint-Jean-sur-Richelieu, Quebec
J2X 5K8
Canada
Tel.: (450) 358-4600
Toll-free: 1-800-831-AUBE
Fax: (450) 358-4650
Email: aube.service@honeywell.com

For more information on our products, go to
www.aubetech.com



As an ENERGY STAR® partner, Aube Technologies has determined that this product meets the ENERGY STAR guidelines for energy efficiency.